



Product Summary

The RMC41 is a 2-port unmanaged Ethernet switch that provides both copper-to-fiber media conversion as well as 10Mbps to 100Mbps speed conversion. Specifically designed to operate reliably in electrically and climatically harsh environments it is well suited for use in mission critical Ethernet networking applications.

The RMC41 is packaged in a compact, galvanized steel enclosure that allows either DIN or panel mounting for efficient use of cabinet space. It has an integrated power supply with a wide range of voltages for worldwide operability. An operating temperature range of -40 to +85°C (-40 to +185°F) without the use of internal cooling fans allows it to be placed in almost any location. It is compliant with EMI and environmental standards for utility substations, industrial plants, and intelligent transportation systems.

The versatility and wide selection of fiber optics allows the RMC41 to be used in a variety of applications. It can be used in place of traditional copper-to-fiber media converters with the added ability to convert speed from 10Mbps to 100Mbps.

All RuggedCom products are backed by a five year warranty and unsurpassed technical support.

Key Features

2-Ethernet Ports with Optional Dual Fiber Optics

- T1 10/100TX port + 1 100FX port (SC/ST)
- Multimode and single mode optical transceivers
- Industry standard fiber optical connectors: SC, ST
- Long haul optics allow distances from 20km to 90km

Universal Power Supply Options

- Input voltages of 24VDC, 48VDC, and (88-300VDC or 85-264VAC) for worldwide operability
- Integrated power supply eliminates need for an awkward external power transformer
- Screw down terminal blocks ensure reliable maintenance free connections
- CSA/UL 60950 safety approved to +85°C

Designed for Harsh Environments

- Exceeds IEC 61850-3 and IEEE 1613 Standards for Communication Equipment in Electric Power Substations
- Exceeds NEMA TS-2 Standard for Traffic Control Equipment
- Operates over a temperature range of -40°C to +85°C without the use of fans for improved reliability
- 21 AWG galvanized steel enclosure and DIN or panel mounting options provide secure mechanical reliability

High Performance Ethernet Switching

- Full compliance with IEEE 802.3 and IEEE 802.3u Ethernet standards for universal interoperability
- Non-blocking, store and forward switching with only 10us latency means high network throughput
- Full duplex operation results in no collisions and deterministic network response and flow control via 802.3x pause frames results in no collisions or dropped packets

Simple Plug and Play Operation

- Automatic learning of up to 2048 MAC addresses
- Auto-negotiation on the 10/100TX port simplifies setup
- Auto-MDI/MDIX on the 10/100TX port eliminates need for crossover cables
- LED indicators for link, activity, and speeds LED aids in field trouble-shooting

EMI and Environmental Type Tests

IEC 61850-3 EMI TYPE TESTS				
TEST	Description		Test Levels	Severity Levels
IEC 61000-4-2	ESD	Enclosure Contact	+/- 8kV	4
		Enclosure Air	+/- 15kV	4
IEC 61000-4-3	Radiated RFI	Enclosure ports	20 V/m	x
IEC 61000-4-4	Burst (Fast Transient)	Signal ports	+/- 4kV @ 2.5kHz	x
		D.C. Power ports	+/- 4kV	4
		A.C. Power ports	+/- 4kV	4
		Earth ground ports ³	+/- 4kV	4
IEC 61000-4-5	Surge	Signal ports	+/- 4kV line-to-earth, +/- 2kV line-to-line	4
		D.C. Power ports	+/- 2kV line-to-earth, +/- 1kV line-to-line	3
		A.C. Power ports	+/- 4kV line-to-earth, +/- 2kV line-to-line	4
IEC 61000-4-6	Induced (Conducted) RFI	Signal ports	10V	3
		D.C Power ports	10V	3
		A.C. Power ports	10V	3
		Earth ground ports ³	10V	3
IEC 61000-4-8	Magnetic Field	Enclosure ports	40 A/m continuous, 1000 A/m for 1 s	N/A
IEC 61000-4-29	Voltage Dips & Interrupts	D.C. Power ports	30% for 0.1s, 60% for 0.1s, 100% for 0.05s	N/A
IEC 61000-4-11		A.C. Power ports	30% for 1 period, 60% for 50 periods 100% for 5 periods, 100% for 50 periods ²	N/A
IEC 61000-4-12	Damped Oscillatory	Signal ports	2.5kV common, 1kV diff. mode@1MHz	3
		D.C. Power ports	2.5kV common, 1kV diff. mode@1MHz	3
		A.C. Power ports	2.5kV common, 1kV diff. mode@1MHz	3
IEC 61000-4-16	Mains Frequency Voltage	Signal ports	30V Continuous, 300V for 1s	4
		D.C. Power ports	30V Continuous, 300V for 1s	4
IEC 61000-4-17	Ripple on D.C. Power Supply	D.C. Power ports	10%	3
IEC 60255-5	Dielectric Strength	Signal ports	2kVac (Fail-Safe Relay output)	N/A
		D.C. Power ports	2kVac	N/A
		A.C. Power ports	2kVac	N/A
IEC 60255-5	H.V. Impulse	Signal ports	5kV (Fail-Safe Relay output)	N/A
		D.C. Power ports	5kV	N/A
		A.C. Power ports	5kV	N/A

IEEE 1613 (C37.90.x) EMI IMMUNITY TYPE TESTS				
Test	Description		Test Levels	Severity Levels
IEEE C37.90.3	ESD	Enclosure Contact	+/- 8kV	N/A
		Enclosure Air	+/- 15kV	N/A
IEEE C37.90.2	Radiated RFI	Enclosure ports	35 V/m	N/A
IEEE C37.90.1	Fast Transient	Signal ports	+/- 4kV @ 2.5kHz	N/A
		D.C. Power ports	+/- 4kV	N/A
		A.C. Power ports	+/- 4kV	N/A
		Earth ground ports ³	+/- 4kV	N/A
IEEE C37.90.1	Oscillatory	Signal ports	2.5kV common mode @1MHz	N/A
		D.C. Power ports	2.5kV common, 1kV diff. mode@1MHz	N/A
		A.C. Power ports	2.5kV common, 1kV diff. mode@1MHz	N/A
IEEE C37.90	H.V. Impulse	Signal ports	5kV (Fail-Safe Relay output)	N/A
		D.C. Power ports	5kV	N/A
		A.C. Power ports	5kV	N/A
IEEE C37.90	Dielectric Strength	Signal ports	2kVac	N/A
		D.C. Power ports	2kVac	N/A
		A.C. Power ports	2kVac	N/A

Environmental Type Tests				
Test	Description		Test Levels	Severity Levels
IEC 60068-2-1	Cold Temperature	Test Ad	-40°C, 16 Hours	N/A
IEC 60068-2-2	Dry Heat	Test Bd	+85°C, 16 Hours	N/A
IEC 60068-2-30	Humidity (Damp Heat, Cyclic)	Test Db	95% (non-condensing), 55°C , 6 cycles	N/A
IEC 60255-21-1	Vibration	Tests Fc	2g @ (10 - 150) Hz	Class 2
IEC 60255-21-2	Shock	Tests Ea	30g @ 11mS	Class 2

Notes: 1. Only applicable to functional earth connections separated from the safety earth connection.
2. Class 2 refers to "Measuring relays and protection equipment for which a very high security margin is required or where the vibration levels are very high, (e.g. shipboard application and for severe transportation conditions")

Technical Specifications

Power Supply

- Power Consumption: 5W (max)
- 24VDC: 18-36VDC (max)
- 48VDC: 36-59VDC (max)
- HI Voltage AC/DC: 88-300VDC, 85-265VAC (max)

Physical

- Height: 4.3"
- Width: 2.3"
- Depth: 3.7" (Max)
- Weight: 1.5lbs (0.68kg)
- Ingress Protection: IP40 (1mm objects)
- Enclosure: 21 AWG galvanized steel enclosure
- Mounting: DIN rail or panel mounted

EMI Immunity and Environmental Compliance

- IEC 61000-6-2 Industrial (Generic)
- IEC 61800-3 Industrial (Variable Speed Drive Systems)
- IEC 61850-3 Electric Utility Substations
- IEEE 1613 Electric Utility Substations
- NEMA TS 2 Traffic Control Equipment

IEEE Compliance

- 802.3-10BaseT
- 802.3u-100BaseTX, 100BaseFX
- 803.x-Flow Control

Approvals

- ISO: Designed and manufactured using a ISO9001: 2000 certified quality program
- CE Marking
- Emissions: FCC Part 15 (Class A), EN55022 (CISPR22 Class A)
- Safety: cCSAus (Compliant with CSA C22.2 No. 60950, UL 60950, EN60950)
- Laser Eye Safety (FDA/CDRH): Complies with 21 CFR Chapter1, Subchapter J.

Warranty

- 5 Years-Applicable to design or manufacturing related product defects.

Fiber Optical Specifications				
Parameter	Fiber Port Type			
Mode	Multimode	Singlemode		
Connectors	ST / SC	SC		
Typical Dist. (km)	2	20	50	90
Optical Wavelength (nm)	1310	1310		
Cable Size Core/Cladding (um)	50 or 62.5/125	8 or 9/125		
Tx Power (dBm)	-15.7	-15.5	-2.5	2.5
Rx Sensitivity (dBm)	-33.5	-32	-37	-39
Typical Budget	17	16.5	34.5	41.5

Longer segment lengths dependent on fiber specifications. Consult factory for further details.

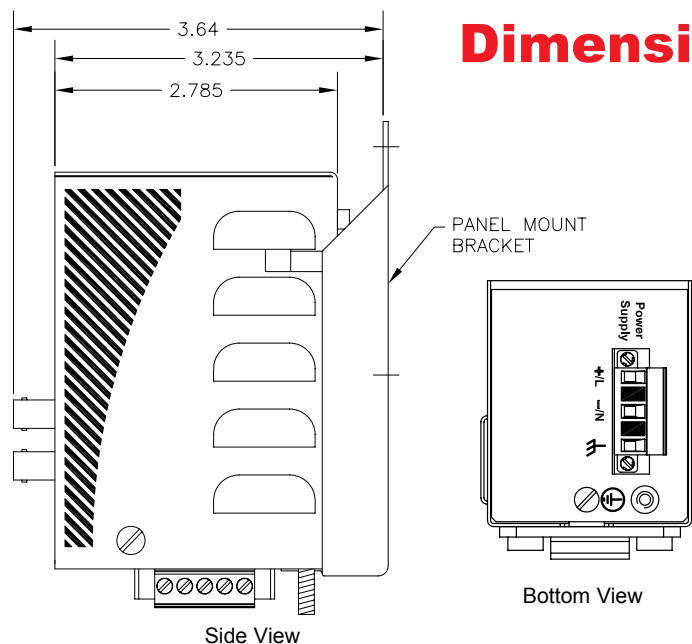
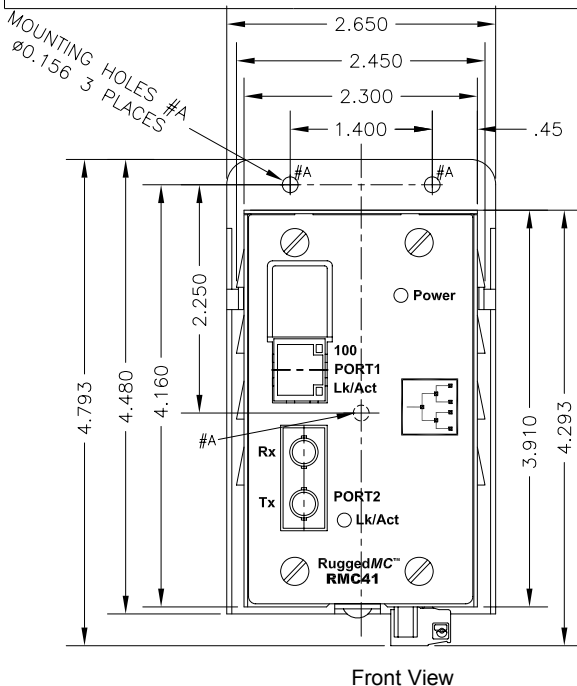

Dimensions

Order Codes

RMC41 - -
 PS - P2

PS: Power Supply

- 24 = 24VDC (18-36VDC)
- 48 = 48 VDC (36-59VDC)
- HI = 88-300VDC or 85-264VAC

P2: Ethernet Port 2

- MC = Multimode SC
- MT = Multimode ST
- C2 = Singlemode SC (20km)
- C5 = Singlemode SC (50km)
- C9 = Singlemode SC (90km)

Valid Order Code Examples

- RMC41-24-MC:
24DC power, 1 10/100TX port,
1 100FX Multimode SC optical port
- RMC41-48-C200:
48DC power, 1 10/100TX port,
1 100FX Singlemode SC optical port

Mounting Options

- DIN rail mounting is standard
- For Panel mounting, order P/N 41-12-006

For additional information on our products and services, please visit our website at: www.ruggedcom.com

RuggedCom Inc.
30 Whitmore Road
Woodbridge, Ontario, Canada L4L 7Z4
Tel: +1 (905) 856-5288 Fax: +1 (905) 856-1995
Toll Free: +1 (888) 264-0006
Technical Support Center: +1 (866) 922-7975

© 2009 RuggedCom Inc.
RuggedMC is a trademark of RuggedCom Inc.
Ethernet is a trademark of the Xerox Corporation.
Modbus is a trademark of Schneider Electric
All brand marks, trademarks and company names used are exclusively owned by their respective holders.
Patent Pending
All specifications in this document are subject to change without notice.

Rev 1-A -07132009