



The RuggedWireless™ RS910W is an industrially hardened wireless Serial/Ethernet Device Server that has been specifically designed to operate reliably in electrically harsh and climatically demanding environments. The RS910W features a wireless LAN (WLAN) interface combined with 2 serial ports and/or 2 Fast Ethernet ports. The RS910W allows you to connect any RS-232/ 422/485 serial devices at up to 230 kbps and/or connect Ethernet devices for wireless access and control via an IEEE 802.11i wireless LAN. The RS910W eliminates costly wiring and simplifies network installation.

The RS910W functions as a wireless “client/bridge” within an IEEE 802.11b/g compliant WLAN. This allows the RS910W to transfer data for connected serial port and Ethernet devices via an installed Wireless Access Point. The RS910W is capable of wireless data rates of up to 54Mbps whose bandwidth is available for the combined device traffic volume emanating from two serial ports and two Ethernet ports.

Static authentication support is provided by WPA-PSK. For authentication by an access point and a RADIUS server, the RS910W supports IEEE 802.1X/RADIUS for wireless user traffic and distributing dynamic encryption keys. All wireless communications are protected by the very latest “robust security networks” features including strong encryption protocols using WPA with TKIP and even WPA2/802.11i with 128-bit AES encryption. Static authentication support is provided by WPA-PSK. For additional centralized control, the RS910W also supports IEEE 802.1X/RADIUS for wireless user traffic and distributing dynamic encryption keys.

The RS910W has an operating temperature range of -40 to +85°C without the use of internal cooling fans allowing it to be placed in almost any location. The RS910W also has an integrated power supply with a wide range of voltages for worldwide operability, and is compliant with EMI and environmental standards for utility substations, industrial manufacturing, process control and intelligent transportation systems applications.

The RS910W is backed by a five year warranty and unsurpassed technical support.

Features and Benefits

Serial Device Server

- 2 fully compliant EIA/TIA RS485/RS422/RS232 serial ports (software selectable)
- DB9 or RJ45 connectors

- Baud rates up to 230 kbps
- Built-In optional RS485 Termination

Ethernet Ports

- 2 - Fast Ethernet ports (10/100BaseTX or 100 BaseFX)
- Multiple fiber connector types

Cyber Security

- WPA (Wi-Fi Protected Access) with TKIP for enhanced security and encryption
- WPA2/802.11i with CCMP for robust security and 128-bit AES encryption
- IEEE 802.1X/RADIUS using EAP-PEAP for secure “enterprise class” authentication configuration
- Pre-shared Key Mode (PSK) for “personal” mode authentication configuration
- Multi-level user passwords
- SSH/SSL (128-bit encryption)
- Enable/disable ports, MAC based port security
- Port based network access control (802.1x)
- VLAN (802.1Q) to segregate and secure network traffic
- RADIUS centralized password management
- SNMPv3 authentication and 56-bit encryption

Rugged Operating System (ROS®) Features

- Simple plug and play operation - automatic learning, negotiation, and crossover detection
- MSTP (802.1Q-2005, formerly 802.1s)
- RSTP (802.1D-2004) and Enhanced Rapid Spanning Tree (eRSTP™) network fault recovery (<5ms)
- Quality of Service (802.1p) for real-time traffic
- VLAN (802.1Q) with double tagging and GVRP support
- Link aggregation (802.3ad)
- IGMP Snooping for multicast filtering
- Port Rate Limiting and Broadcast Storm Limiting
- Port configuration, status, statistics, mirroring, security
- SNTP time synchronization (client and server)

RuggedRated™ for Reliability in Harsh Environments

- Immunity to EMI and heavy electrical surges
 - Meets IEEE 1613 (electric utility substations)
 - Exceeds IEC 61850-3 (electric utility substations)
 - Exceeds IEC 61800-3 (variable speed drive systems)
 - Exceeds IEC 61000-6-2 (generic industrial)
 - Exceeds NEMA TS-2 (traffic control equipment)
- -40°C to +85°C operating temperature (no fans)
- 20 AWG galvanized steel enclosure
- DIN or panel mounting options provide secure mechanical reliability
- Hazardous Locations: Class 1, Division 2

Universal Power Supply

- Fully integrated power supplies (no external adaptors)
- Popular low-voltage DC ranges: 24VDC, 48VDC
- Universal high-voltage range: 88-300VDC or 85-264VAC
- CSA/UL 60950 safety approved to +85°C
- Screw down terminal blocks ensure reliable maintenance free connections



RuggedWIRELESS™ RS910W

Fast Ethernet Ports:

- ▶ 2 - Fast Ethernet Ports
- ▶ 10/100BaseTX or 100BaseFX
- ▶ Multiple Fiber connector types

Operating Temperature

- ▶ -40°C to +85°C
- ▶ No Fans

Antenna

- ▶ Standard 3dBi
- ▶ Various antenna option packages available

Rugged Construction:

- ▶ 20 AWG. galvanized steel enclosure
- ▶ Conformal coating (optional)

Serial Ports:

- ▶ 2 RS485/RS422/RS232
- ▶ DB9 or RJ45
- ▶ Up to 230kbp

Hazardous Location Certification

- ▶ Class1, Division2

Critical Alarm Relay

- ▶ Form-C failsafe contact relay: 1A@30VDC

Integrated Power Supply

- ▶ Universal high-voltage range: 88-300VDC or 85 - 264VAC
- ▶ Popular low voltage DC ranges: 24VDC (10-36VDC), 48VDC (36-72VDC)
- ▶ Dual Isolated DC power inputs

Mounting Options

- ▶ DIN Rail
- ▶ Panel Mount



Wireless Specifications

- IEEE 802.11b/g compliant provides simultaneous support for both IEEE802.11b and IEEE802.11g wireless clients.
- Can be configured as an access, client or bridge device
- Antenna type: Removable, upgradeable 3dBi Antenna with R-SMA (male) connector
- Operating channels/frequency-range:
 - 11 channels, 2.400 - 2.4720 Ghz (US, Canada)
 - 13 channels, 2.400 - 2.4835 Ghz (ETSI)
 - 14 channels, 2.400 - 2.4970 Ghz (Japan)
- Data rates:
 - IEEE 802.11b: 11/5.5/2/1 Mbps with automatic failback
 - IEEE 802.11g: 54/48/36/24/18/12/9/6 Mbps with automatic failback
- Modulation technology:
 - IEEE 802.11b: DSSS over CCK (11/5 Mbps), DQPSK (2 Mbps), DBPSK (1 Mbps)
 - IEEE 802.11g: OFDM over 64QAM, 16QAM, QPSK, BPSK
- Transmit power:
 - IEEE 802.11b: 20dBm nominal @ 11 Mbps
 - IEEE 802.11g: 16dBm nominal @ 54 Mbps
- Receiver sensitivity:
 - IEEE 802.11b: -88dBm @ 11 Mbps with 8% FER
 - IEEE 802.11g: -74dBm @ 54 Mbps with 10% FER

ROS® Features



Serial IP Encapsulation

Many 'legacy' devices (RTU, PLC, IED, etc.) only support serial communications via RS232, RS422 or RS485. ROS® encapsulates the serial data within a TCP connection allowing these devices to be reached via an IP network. A wide range of baud rates, frame packetization options, and diagnostics allows any serial protocol to function. The RS910W has specific support for the following serial protocols:

- Raw Socket serial encapsulation
- Modbus TCP (client and server)
- DNP 3
- WIN and TIN
- Microlok

MODBUS TCP

The Modbus protocol is ubiquitous in the industrial control and automation world. ROS® converts Modbus RTU master/slave serial data packets to Modbus TCP client/server packets for transmission over an IP network. This allows communications to Modbus RTU slaves via Ethernet and allows multiple masters to poll the same slave device.

Cyber Security

Cyber security is an urgent issue in many industries where advanced automation and communications networks play a crucial role in mission critical applications and where high reliability is of paramount importance. Key ROS® features that address security issues at the local area network level include:

- **Passwords** - Multi-level user passwords secures switch against unauthorized configuration
- **SSH / SSL** - Extends capability of password protection to add 128-bit encryption of passwords and data as they cross the network
- **Enable/Disable Ports** - Capability to disable ports so that traffic can not pass
- **802.1Q VLAN** - Provides the ability to logically segregate traffic between predefined ports on switches
- **MAC Based Port Security** - The ability to secure ports on a switch so only specific Devices / MAC addresses can communicate via that port
- **802.1x Port Based Network Access Control** - The ability to lock down ports on a switch so that only authorized clients can communicate via this port
- **RADIUS** - authentication service using MD5 hash and providing centralized password management
- **SNMPv3** - encrypted authentication access security and data encryption (CBC-DES with 56-bit encryption key)
- **Secure Socket Layer** - Web-based management using SSL with data encryption (128-bit encryption key)
- **RSA** - 1024 bit key for key management and key exchange
- **TACACS+** - Terminal Access Control and Accounting Services Client provides encrypted authentication and authorization

- **Point to Point (PPP)** - using CHAP (MD5 Hash) authentication service
- **SFTP** - Secure File Transfer Protocol using SSH encryption

The ROS® cyber security features are included to help address the various industry specific security standards such as NERC CIP, ISA S99, AGA 12, IEC 62443, ISO 17799:2005 and PCSRF SPP-ICS.

Enhanced Rapid Spanning Tree Protocol (eRSTP™)

RuggedCom eRSTP™ allows the creation of fault-tolerant ring and mesh Ethernet networks that incorporate redundant links that are 'pruned' to prevent loops. eRSTP™ yields worst-case fault recovery¹ of 5ms times the 'bridge diameter' and allows rings of up to 160 switches. For example, a ring of ten switches will have fault recovery times under 50ms. eRSTP™ implements both STP and RSTP to ensure interoperability with commercial switches unlike other proprietary 'ring' solutions.

Quality of Service (IEEE 802.1p)

Some networking applications such as real-time control or VoIP (voice over IP) require predictable arrival times for Ethernet frames. Switches can introduce latency in times of heavy network traffic due to the internal queues that buffer frames and then transmit on a first come first serve basis. ROS® supports 'Class of Service' in accordance with IEEE 802.1p that allows time critical traffic to jump ahead to the front of the queue thus minimizing latency and reducing jitter to allow such demanding applications to operate correctly. ROS® allows priority classification by port, tags, MAC address, and IP type of service (ToS).

A configurable "weighted fair queuing" algorithm controls how frames are emptied from the queues.

VLAN (IEEE 802.1Q)

Virtual local area networks (VLAN) allow the segregation of a physical network into separate logical networks with independent broadcast domains. A measure of security is provided since hosts can only access other hosts on the same VLAN and traffic storms are isolated. ROS® supports 802.1Q tagged Ethernet frames and VLAN trunks. Port based classification allows legacy devices to be assigned to the correct VLAN. GVRP support is also provided to simplify the configuration of the switches on the VLAN.

Link Aggregation (802.3ad)

The link aggregation feature provides the ability to aggregate several Ethernet ports into one logical link (port trunk) with higher bandwidth. This provides an inexpensive way to set up a high speed backbone to improve network bandwidth. This feature is also known as "port trunking", "port bundling", "port teaming", and "Ethernet trunk".

IGMP Snooping

ROS® uses IGMP snooping (Internet Group Management Protocol v1&v2) to intelligently forward or filter multicast traffic streams (e.g. MPEG video) to or from hosts on the network.

ROS® Features



This reduces the load on network trunks and prevents packets from being received on hosts that are not involved. ROS® has a very powerful implementation of IGMP snooping that:

- Can be enabled on a per VLAN basis.
- Detects and filters all multicast streams regardless of whether subscribers exist.
- Supports “router-less” operation by supporting an “active” mode.
- Restores traffic streams immediately after an RSTP topology change.

SNMP (Simple Network Management Protocol)

SNMP provides a standardized method for network management stations the ability to interrogate devices from different vendors. SNMP versions supported by ROS® are v1, v2c, and v3. SNMPv3 in particular provides security features such as authentication, privacy with data encryption (CBC-DES with 56-bit encryption key) and access control not present in earlier SNMP versions. ROS® also supports numerous standard MIBs (Management Information Base) allowing for easy integration with any network management system (NMS). A feature of SNMP supported by ROS® is the ability to generate “traps” upon system events. RuggedNMS™, the RuggedCom management solution, can record traps from multiple devices providing a powerful network troubleshooting tool. It also provides a graphical visualization of the network and is fully integrated with all RuggedCom products.

SCADA and Industrial Automation

ROS® contains features that optimize network performance and simplify switch management based on the unique requirements found in SCADA and industrial automation applications. Features such as Modbus TCP management for retrieval of switch data using the ubiquitous Modbus protocol and DHCP Option 82, a Rockwell Automation ODVA requirement for IP address assignment based on the location of the end device, provide capabilities not found in typical “commercial” or “office grade” Ethernet switches.

Port Based Network Access Control (802.1x)

ROS® supports the IEEE 802.1x standard that defines a mechanism for port-based network access control which provides a means of authenticating and authorizing devices attached to LAN ports.

Port Rate Limiting

ROS® supports configurable rate limiting per port to limit unicast and multicast traffic. This can be essential to managing precious network bandwidth for service providers. It also provides edge security for denial of service (DoS) attacks.

Broadcast Storm Filtering

Broadcast storms wreak havoc on a network and can cause attached devices to malfunction. This could be disastrous on a network with mission critical equipment. ROS® limits this by filtering broadcast frames with a user-defined threshold.

Port Mirroring

ROS® can be configured to duplicate all traffic on one port to a designated mirror port. When combined with a network analyzer, this can be a powerful troubleshooting tool.

Port Configuration and Status

ROS® allows individual ports to be ‘hard’ configured for speed, duplex, auto-negotiation, flow control and more. This allows proper connection with devices that do not negotiate or have unusual settings. Detailed status of ports with alarm and SNMP trap on link problems aid greatly in system troubleshooting.

Port Statistics and RMON (Remote Monitoring)

ROS® provides continuously updating statistics per port that provide both ingress and egress packet and byte counters as well as detailed error figures. Also provided is full support for the RMON statistics, history, alarms, and event groups. RMON allows for very sophisticated data collection, analysis and detection of traffic patterns.

Event Logging and Alarms

ROS® records all significant events to a non-volatile system log allowing forensic troubleshooting. Events include link failure and recovery, unauthorized access, broadcast storm detection, and self-test diagnostics among others. Alarms provide a snapshot of recent events that have yet to be acknowledged by the network administrator. An external hardware relay is de-energized during the presence of critical alarms allowing an external controller to react if desired.

HTML Web Browser and Telnet User Interfaces

ROS® provides a simple, intuitive user interface for configuration and monitoring via a standard graphical web browser or via Telnet. All system parameters include detailed on-line help to make setup a breeze. ROS®, presents a common look and feel and standardized configuration process allowing easy migration to other RuggedCom managed products.

Configuration via ASCII Text File

All configuration parameters are stored in an ASCII formatted text file that can easily be transferred via TFTP or Xmodem. The configuration file can be saved for backup purposes and easily manipulated by a text editor. The same text file can be downloaded to the switch at a later date in order to re-configure or restore a previous configuration.

Command Line Interface (CLI)

A command line interface can be used in conjunction with remote shell to automate data retrieval, configuration updates, and firmware upgrades. A powerful SQL-like capability allows expert users the ability to selectively retrieve or manipulate any parameters the device has to offer.

1 eRSTP™ fault recovery times may be approximated as follows:

For 100 Mbps, fault recovery performance is <5ms/hop

For 1,000 Mbps, fault recovery performance is <5ms/hop + 20ms

Network Architecture

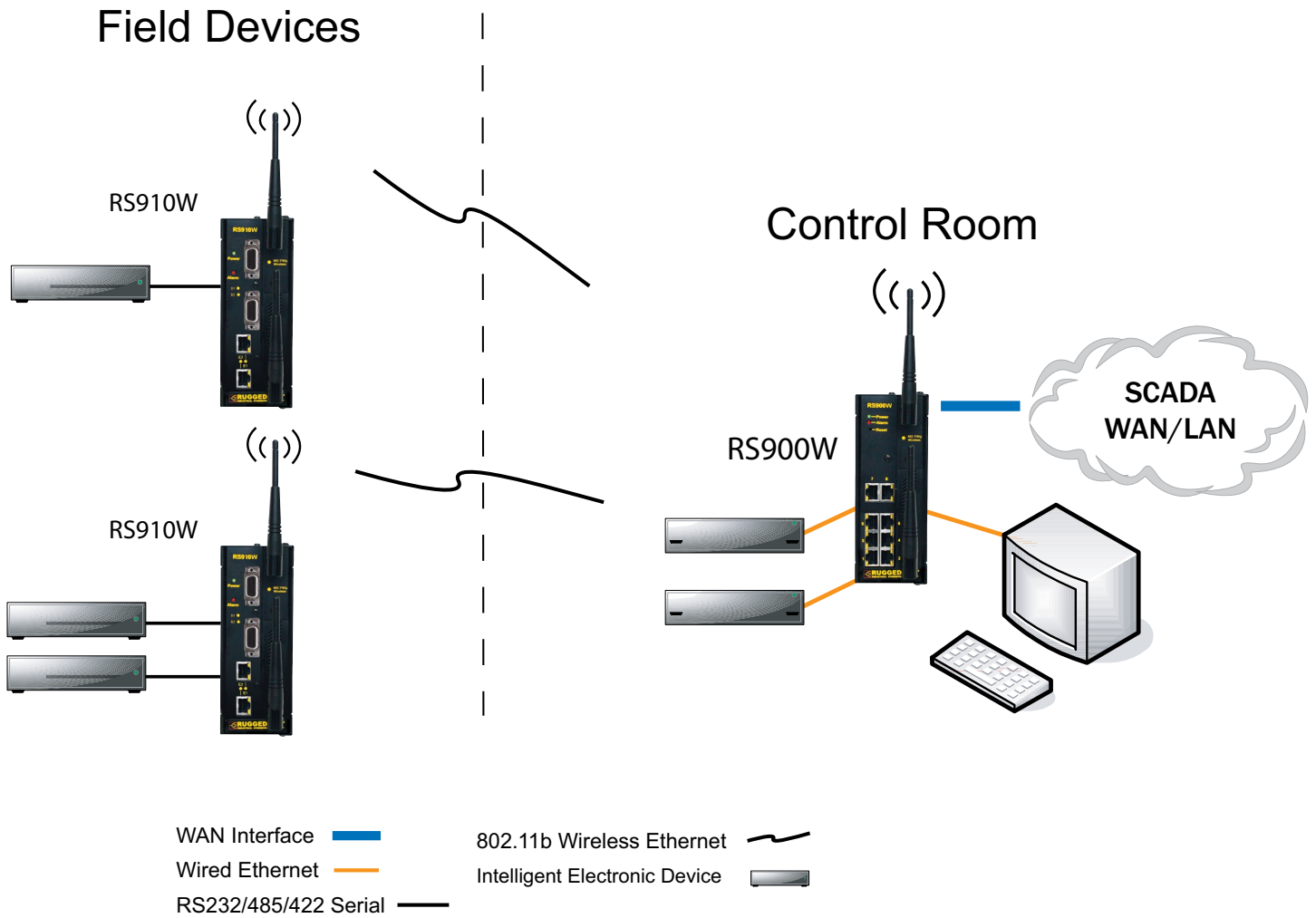

EMI and Environmental Type Tests

IEC 61850-3 EMI TYPE TESTS				
TEST	Description		Test Levels	Severity Levels
IEC 61000-4-2	ESD	Enclosure Contact	+/- 8kV	4
		Enclosure Air	+/- 15kV	4
IEC 61000-4-3	Radiated RFI	Enclosure ports	20 V/m	Note 1
IEC 61000-4-4	Burst (Fast Transient)	Signal ports	+/- 4kV @ 2.5kHz	Note 1
		D.C. Power ports	+/- 4kV	4
		A.C. Power ports	+/- 4kV	4
		Earth ground ports	+/- 4kV	4
IEC 61000-4-5	Surge	Signal ports	+/- 4kV line-to-earth, +/- 2kV line-to-line	4
		D.C. Power ports	+/- 2kV line-to-earth, +/- 1kV line-to-line	3
		A.C. Power ports	+/- 4kV line-to-earth, +/- 2kV line-to-line	4
IEC 61000-4-6	Induced (Conducted) RFI	Signal ports	10V	3
		D.C Power ports	10V	3
		A.C. Power ports	10V	3
		Earth ground ports	10V	3
IEC 61000-4-8	8 Magnetic Field	Enclosure ports	40 A/m continuous, 1000 A/m for 1 s 1000 A/m for 1 s	Note 1 5
IEC 61000-4-29	Voltage Dips & Interrupts	D.C. Power ports	30% for 0.1s, 60% for 0.1s, 100% for 0.05s	N/A
IEC 61000-4-11		A.C. Power ports	30% for 1 period, 60% for 50 periods	N/A
			100% for 5 periods, 100% for 50 periods	N/A
IEC 61000-4-12	Damped Oscillatory	Signal ports	2.5kV common, 1kV diff. mode@1MHz	3
		D.C. Power ports	2.5kV common, 1kV diff. mode@1MHz	3
		A.C. Power ports	2.5kV common, 1kV diff. mode@1MHz	3
IEC 61000-4-16	Mains Frequency Voltage	Signal ports	30V Continuous, 300V for 1s	4
		D.C. Power ports	30V Continuous, 300V for 1s	4
IEC 61000-4-17	Ripple on D.C. Power Supply	D.C. Power ports	10%	3
IEC 60255-5	Dielectric Strength	Signal ports	2kVac (Fail-Safe Relay output)	N/A
		D.C. Power ports	1.5kV DC	N/A
		A.C. Power ports	2kVac	N/A
IEC 60255-5	H.V. Impulse	Signal ports	5kV (Fail-Safe Relay output)	N/A
		D.C. Power ports	5kV	N/A
		A.C. Power ports	5kV	N/A

IEEE 1613 (C37.90.x) EMI IMMUNITY TYPE TESTS ²				
Test	Description		Test Levels	
IEEE C37.90.3	ESD	Enclosure Contact	+/-2kV, +/-4kV, +/- 8kV	
		Enclosure Air	+/-4kV, +/-8kV, +/-15kV	
IEEE C37.90.2	Radiated RFI	Enclosure ports	35 V/m	
IEEE C37.90.1	Fast Transient	Signal ports	+/- 4kV @ 2.5kHz	
		D.C. Power ports	+/- 4kV	
		A.C. Power ports	+/- 4kV	
		Earth ground ports ³	+/- 4kV	
IEEE C37.90.1	Oscillatory	Signal ports	2.5kV common mode @1MHz	
		D.C. Power ports	2.5kV common, 1kV diff. mode@1MHz	
		A.C. Power ports	2.5kV common, 1kV diff. mode@1MHz	
IEEE C37.90	H.V. Impulse	Signal ports	5kV (Fail-Safe Relay output)	
		D.C. Power ports	5kV	
		A.C. Power ports	5kV	
IEEE C37.90	Dielectric Strength	Signal ports	2kVac	
		D.C. Power ports	1.5kV DC	
		A.C. Power ports	2kVac	

Environmental Type Tests				
Test	Description		Test Levels	
IEC 60068-2-1	Cold Temperature	Test Ad	-40°C, 16 Hours	
IEC 60068-2-2	Dry Heat	Test Bd	+85°C, 16 Hours	
IEC 60068-2-30	Humidity (Damp Heat, Cyclic)	Test Db	95% (non-condensing), 55°C , 6 cycles	
IEC 60255-21-1	Vibration		2g @ (10 - 150) Hz	
IEC 60255-21-2	Shock		30g @ 11mS	

Technical Specifications

Power Supply

- Power Consumption: 10W Max
- 24VDC: 10-36VDC, 0.4A
- 48VDC: 36-72VDC, 0.2A
- HI Voltage AC/DC: 88-300VDC, 85-264VAC, 0.1A

Critical Alarm Relay

- Form-C failsafe contact relay: 1A@30VDC

Physical

- Height: 7.4" / 18.8cm
- Width: 2.6" / 6.6 cm
- Depth: 5.0" / 12.7cm
- Weight: 2.7lbs / 1.22kg
- Ingress Protection: IP40 (1mm objects)
- Enclosure: 20 AWG galvanized steel enclosure
- Mounting: DIN rail or panel mounted

Switch Properties

- Switching method: Store & Forward
- Switching latency: 8 us (100Mbps)
- Switching bandwidth: 1.8Gbps
- MAC address table size: 16kbytes
- Priority Queues: 4
- Frame buffer memory: 1 Mbit
- Simultaneous VLANs: 255
- VLAN ID Range: 1 to 4094
- IGMP and static multicast groups: 256
- Port rate limiting: 128kbps, 256, 512, 4, 8Mbps
- No head of line blocking

Approvals

- Hazardous Locations: Class 1, Division 2
- ISO: Designed and manufactured using a ISO9001: 2000 certified quality program
- CE Marking
- Emissions: FCC Part 15 (Class A), EN55022 (CISPR22 Class A)
- Safety: cCSAus (Compliant with CSA C22.2 No. 60950, UL 60950, EN60950)
- Laser Eye Safety (FDA/CDRH): Complies with 21 CFR Chapter1, Subchapter J.

EMI Immunity and Environmental Compliance

- IEC 61000-6-2 Industrial (Generic)
- IEC 61800-3 Industrial (Variable Speed Drive Systems)
- IEC 61850-3 Electric Utility Substations
- IEEE 1613 Electric Utility Substations
- NEMA TS 2 Traffic Control Equipment

Network Management

- HTTP graphical web-based, SSL (128-bit encryption)
- SNMP v1, v2c, v3 (56-bit encryption)
- Telnet, VT100, SSH/SFTP (128-bit encryption)
- Command Line Interface (CLI)
- RSA Key Management (1024 bit key)
- Authentication and Accounting - TACACS+ (encrypted), RADIUS client, PPP

Warranty

- 5 Years-Applicable to design or manufacturing related product defects.

IEEE Compliance

- 802.3-10BaseT
- 802.3u-100BaseTX, 100BaseFX
- 802.3x-Flow Control
- 802.3z-1000BaseLX
- 802.3ab-1000BaseTX
- 802.3ad-Link Aggregation
- 802.1D-MAC Bridges
- 802.1D-Spanning Tree Protocol
- 802.1p-Class of Service
- 802.1Q-VLAN Tagging
- 802.11i Security 128-bit AES encryption
- 802.1D-2004-Rapid Spanning Tree Protocol
- 802.1x-Port Based Network Access Control
- 802.1Q-2005 (formerly 802.1s) MSTP

IETF RFC Compliance

- RFC768-UDP
- RFC783-TFTP
- RFC791-IP
- RFC792-ICMP
- RFC793-TCP
- RFC826-ARP
- RFC854-Telnet
- RFC894-IP over Ethernet
- RFC1112-IGMP v1
- RFC1519-CIDR
- RFC1541-DHCP (client)
- RFC2030-SNTP
- RFC2068-HTTP
- RFC2236-IGMP v2
- RFC2284-EAP
- RFC2475-Differentiated Services
- RFC2865-RADIUS
- RFC3414-SNMPv3-USM
- RFC3415-SNMPv3-VACM

IETF SNMP MIBS

- RFC1493-BRIDGE-MIB
- RFC1907-SNMPv2-MIB
- RFC2012-TCP-MIB
- RFC2013-UDP-MIB
- RFC2578-SNMPv2-SMI
- RFC2579-SNMPv2-TC
- RFC2819-RMON-MIB
- RFC2863-IF-MIB
- draft-ietf-bridge-rstpmib-03-BRIDGE-MIB
- draft-ietf-bridge-bridgemib-smiv2-03-RSTP-MIB
- IANAifType-MIB

Fiber Specifications and Mechanical Drawing

Fiber Optical Specifications				
Parameter	Fiber Port Type			
Mode	Multimode	Singlemode		
Connectors	MTRJ / ST / SC / LC	LC / SC / ST		
Typical Dist. (km)	2	20	50	90
Optical Wavelength (nm)	1310	1310		
Cable Size Core/Cladding (um)	50 or 62.5/125	8 or 9/125		
Tx Power (dBm)	-15.7	-15.5	-2.5	2.5
Rx Sensitivity (dBm)	-33.5	-32	-37	-39
Typical Budget (dB)	17	16.5	34.5	41.5

Longer segment lengths dependent on fiber specifications. Consult factory for further details.

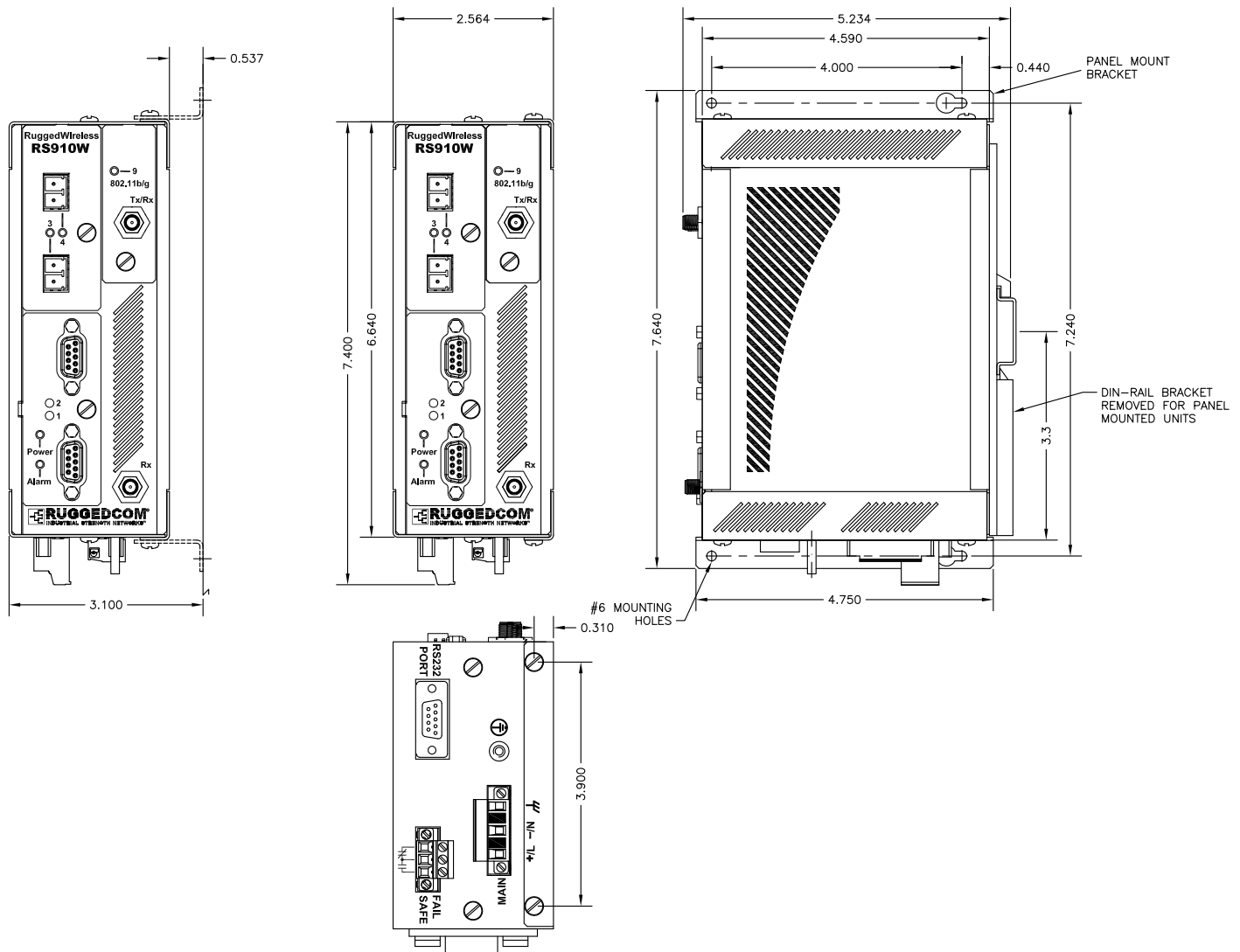

Order Code

RS910W - - - - - -

PS M S E WW MOD

PS: Power Supply

- 24 = 24 VDC (10-36 VDC)
- 48 = 48 VDC (36-59 VDC)
- HI = 85-264VAC or 88-300VDC

M: Mounting options

- D = Din Rail
- P = Panel Mounting
- N = None

S: Serial Port Options

- XX = None
- S1 = 2 x RS232/422/485 DB9
- S2 = 2 x RS232/422/485 RJ45
- S3 = 2 x Fiber 850nm ST

E: Ethernet Ports Options

- XXXX = No Ethernet ports
- TX01 = 2 x 10/100Tx RJ45
- FL01 = 2 x 10FL - Multimode, 850 nm, ST connectors
- FX01 = 2 x 100FX - Multimode, 1300 nm, ST connectors
- FX02 = 2 x 100FX - Multimode, 1300 nm, SC connectors
- FX03 = 2 x 100FX - Multimode, 1300 nm, MTRJ connectors
- FX11 = 2 x 100FX - Multi mode, 1300nm, LC connectors
- FX04 = 2 x 100FX - Singlemode, 1300 nm, ST connectors, 20km
- FX05 = 2 x 100FX - Singlemode, 1300 nm, SC connectors, 20km
- FX06 = 2 x 100FX - Singlemode, 1300 nm, LC connectors, 20km
- FX07 = 2 x 100FX - Singlemode, 1300 nm, SC connectors, 50km
- FX08 = 2 x 100FX - Singlemode, 1300 nm, LC connectors, 50km
- FX09 = 2 x 100FX - Singlemode, 1300 nm, SC connectors, 90km
- FX10 = 2 x 100FX - Singlemode, 1300 nm, LC connectors, 90km

WW: Wireless Options

- W1 = 802.11 - US (North America)
- W2 = 802.11 - EU (European Union)
- W3 = 802.11 - CH (China)(Coming soon)
- W4 = 802.11 - AU (Australia)
- W6 = 802.11 - IN (India)

MOD: Manufacturing Modifications

- XX = None
- C01 = Conformal Coating

Power Cables

- 43-10-0008 - Bare-wire
- 43-10-0007 - with lugs

RuggedCom Inc.

300 Applewood Crescent, Unit 1,
Concord, Ontario, Canada L4K 5C7

Tel: +1 (905) 856-5288 **Fax:** +1 (905) 856-1995

Toll Free: 1 (888) 264-0006

Technical Support Center

Toll Free (USA & Canada): 1 (866) 922-7975

International: +1 (905) 856-5288

USA: +1 (954) 922-7975

E-mail: Support@RuggedCom.com

© 2010 RuggedCom Inc.
RuggedSwitch is a registered trademark of RuggedCom Inc.
Ethernet is a trademark of the Xerox Corporation.
Patent Pending
All specifications in this document are subject to change without notice.
Rev 1t — 04/27/10

For additional information on our products and services, please
visit our web site at: www.RuggedCom.com