



# RuggedSwitch® M2200

**MIL-STD 9-Port Modular Managed  
Gigabit Ethernet Switch**



## Installation Guide

July 21, 2010

[www.RuggedCom.com](http://www.RuggedCom.com)

## Copyright

COPYRIGHT © 2010 RuggedCom Inc. ALL RIGHTS RESERVED

Dissemination or reproduction of this document, or evaluation and communication of its contents, is not authorized except where expressly permitted. Violations are liable for damages. All rights reserved, particularly for the purposes of patent application or trademark registration.

This document contains proprietary information, which is protected by copyright. All rights are reserved. No part of this document may be photocopied, reproduced or translated to another language without the prior written consent of RuggedCom Inc.

## Disclaimer of liability

We have checked the contents of this manual against the hardware and software described. However, deviations from the description cannot be completely ruled out.

RuggedCom shall not be liable for any errors or omissions contained herein or for consequential damages in connection with the furnishing, performance, or use of this material.

The information given in this document is reviewed regularly and any necessary corrections will be included in subsequent editions. We appreciate any suggested improvements. We reserve the right to make technical improvements without notice.

## Registered Trademarks

RuggedRated™, ROS™ and eRSTP™ are trademarks of RuggedCom Inc. RuggedRouter® and RuggedSwitch® are registered trademarks of RuggedCom Inc. Other designations in this manual might be trademarks whose use by third parties for their own purposes would infringe the rights of the owner.

## Contacting RuggedCom

| Corporate Headquarters  | US Headquarters  | Europe Headquarters  |
|---|--|--|
| RuggedCom Inc.<br>300 Applewood Crescent<br>Concord, Ontario<br>Canada, L4K 5C7 | RuggedCom<br>1930 Harrison St., Suite 209<br>Hollywood, Florida<br>USA, 33020      | RuggedCom<br>Unit 41, Aztec Centre,<br>Aztec West, Almondsbury, Bristol<br>United Kingdom BS32 4TD |
| Tel: +1 905 856 5288<br>Fax: +1 905 856 1995<br>Toll-free: 1 888 264 0006       | Tel: +1 954 922 7938 ext. 103<br>Fax: +1 954 922 7984<br>Toll-free: 1 888 264 0006 | Tel: +44 1454 203 404<br>Fax: +44 1454 203 403   |
| Email: <a href="mailto:RuggedSales@RuggedCom.com">RuggedSales@RuggedCom.com</a> |  |  |

## Technical Support

Toll Free (North America): 1 866 922 7975  
International: +1 905 856 5288  
Email: [Support@RuggedCom.com](mailto:Support@RuggedCom.com)

Web: [www.RuggedCom.com](http://www.RuggedCom.com)

## Federal Communications Commission Radio Frequency Interference Statement

*This equipment has been tested and found to comply with the limits for a Class A digital device pursuant to Part 15 of the FCC Rules. These limits are designed to provide reasonable protection against harmful interference when the equipment is operated in a commercial environment. This equipment generates, uses and can radiate radio frequency energy and, if not installed and used in accordance with the instruction manual, may cause harmful interference to radio communications. Operation of this equipment in a residential area is likely to cause harmful interference in which case the user will be required to correct the interference at his expense.*

### CAUTION

This product contains a laser system and is classified as a "CLASS 1 LASER PRODUCT"

### CAUTION

Use of controls or adjustments or performance of procedures other than those specified herein may result in hazardous radiation exposure. This product contains no user-serviceable parts. Attempted service by unauthorized personnel shall render all warranties null and void.

Changes or modifications not expressly approved by RuggedCom Inc. could void the user's authority to operate the equipment.

Should this device require service see the "Warranty and Service" section of this guide.

### IMPORTANT

This product should be installed in a restricted access location where access can only be gained by service personnel or users who have been instructed about the reasons for the restrictions applied to the location and about any precautions that shall be taken; and access is through the use of a tool or lock and key, or other means of security, and is controlled by the authority responsible for the location.

### Trademarks:

*Ethernet* is a trademark of Xerox Corporation

*RuggedRated, ROS and eRSTP* are trademarks of RuggedCom® Inc.

*RuggedSwitch®* is a registered trademark of RuggedCom® Inc.

# 1 Table of Contents

|       |   |    |
|-------|---|----|
| 1     | Table of Contents .....                                   | 4  |
| 2     | Table of Figures .....                                    | 5  |
| 3     | Table of Tables.....                                      | 5  |
| 4     | Product Overview .....                                    | 6  |
| 4.1   | Functional Overview & Feature Highlights.....             | 6  |
| 4.2   | Ethernet Panel Description .....                          | 8  |
| 4.2.1 | Fiber Optic Transceiver Orientation and Connection.....   | 9  |
| 4.3   | Display Panel Description.....                            | 10 |
| 5     | Installation .....  | 12 |
| 5.1   | Panel Mounting.....                                       | 12 |
| 5.2   | Power Supply Wiring and Grounding.....                    | 13 |
| 5.2.1 | AC Power Supply Wiring Examples .....                     | 15 |
| 5.2.2 | DC Power Supply Wiring Examples .....                     | 16 |
| 5.2.3 | Dual Power Supplies – DC and AC Inputs.....               | 17 |
| 5.3   | Dielectric Strength (HIPOT) Testing.....                  | 18 |
| 5.4   | Failsafe Alarm Relay Wiring and Specifications.....       | 19 |
| 5.5   | Console Port Wiring .....                                 | 20 |
| 5.6   | Twisted-Pair Data Ports .....                             | 21 |
| 5.6.1 | Micro-D Twisted-Pair Data Ports .....                     | 21 |
| 5.6.2 | Protection on Twisted-Pair Data Ports.....                | 22 |
| 5.7   | Gigabit Ethernet 1000Base-Tx Cabling Recommendations..... | 22 |
| 6     | Technical Specifications .....                            | 23 |
| 6.1   | Power Supply Specifications .....                         | 23 |
| 6.2   | Failsafe Relay Specifications.....                        | 23 |
| 6.3   | Networking Standards Supported .....                      | 24 |
| 6.4   | Twisted-Pair Port Specifications.....                     | 24 |
| 6.5   | Fiber Optic Specifications.....                           | 25 |
| 6.5.1 | Gigabit Ethernet (1000Mbps) Modules .....                 | 25 |
| 6.6   | Operating Environment.....                                | 25 |
| 6.7   | Mechanical Specifications .....                           | 26 |
| 7     | Type Tests.....   | 27 |
| 7.1   | IEC 61850-3 Type Tests .....                              | 27 |
| 7.2   | IEEE 1613 Type Tests .....                                | 27 |
| 7.3   | Military Standard Tests.....                              | 28 |
| 8     | Agency Approvals .....                                    | 29 |
| 9     | Warranty.....   | 29 |

## 2 Table of Figures

|   |    |
|---|----|
| Figure 1: Ethernet panel LED description.....                 | 8  |
| Figure 2: 1000BaseX LC connector .....                        | 9  |
| Figure 3: M2000 Series LED Display Panel .....                | 10 |
| Figure 4: M2200 Panel Mounting Diagram.....                   | 12 |
| Figure 5: M2000 Series Phillips Screw Terminal Block .....    | 13 |
| Figure 6: Chassis Ground Connection .....                     | 13 |
| Figure 7: AC Single Power Supply Wiring Example .....         | 15 |
| Figure 8: AC Dual Redundant Power Supply Wiring Example ..... | 15 |
| Figure 9: DC Power Supply Wiring Examples .....               | 16 |
| Figure 10: DC and AC Power Supply Wiring Examples .....       | 17 |
| Figure 11: Dielectric Strength (HIPOT) Testing.....           | 18 |
| Figure 12: Failsafe Alarm Relay Wiring.....                   | 19 |
| Figure 13: Console port location on display board .....       | 20 |
| Figure 14: M2200 Console cable .....                          | 20 |
| Figure 15: Micro-D port pin configuration .....               | 21 |
| Figure 16: Mechanical Dimensions .....                        | 26 |

## 3 Table of Tables

|   |    |
|---|----|
| Table 1: LED Display – Device status LED behavior definition .....  | 10 |
| Table 2: LED Display Description.....                               | 11 |
| Table 3: M2200 Power terminal block connection description.....     | 14 |
| Table 4: RS232 over RJ45 console cable pin-out .....                | 20 |
| Table 5: Cabling categories and 1000BaseTx compliance defined. .... | 22 |
| Table 6 - IEC 61850-3 Type Tests .....                              | 27 |
| Table 7 - IEEE 1613 Type Tests .....                                | 28 |
| Table 8 – Military Standard Tests.....                              | 28 |

## 4 Product Overview

### 4.1 Functional Overview & Feature Highlights

The RuggedSwitch® M2200 is a MIL-STD hardened, fully managed, modular Gigabit Ethernet switch specifically designed to operate reliably in harsh environments. The M2200's superior ruggedized hardware design coupled with the embedded Rugged Operating System (ROS™) provides improved system reliability, and advanced cyber security and networking features making it ideal for creating secure mission critical real-time control applications, and for aggregating Ethernet switches onto a Gigabit backbone.

The M2200's modular flexibility offers 1000BaseX fiber (LC connectors) and 10/100/1000BaseTX copper port (Micro-D connectors) combinations. The M2200 is packaged in a rugged galvanized steel enclosure and provides MIL-901D shock and vibration immunity. The M2200 is highly versatile and suitable for many applications within a "harsh" environment.

#### Ethernet Ports

- Up to 9-Gigabit Ethernet ports - copper and/or fiber
- 2 port modules for tremendous flexibility
- Supports multimode and singlemode fiber
- Non-blocking, store and forward switching
- Supports LC connectors for fiber, Mirco-D connectors for copper

#### RuggedRated™ for Reliability in Harsh Environments

- Immunity to EMI and heavy electrical surges
- Zero-Packet-Loss™ Technology
- -40 to +85°C operating temperature (no fans)
- Conformal coated printed circuit boards
- 18 AWG galvanized steel enclosure

#### MIL-STD Ratings

- MIL-STD 901D – Shock (Hard Mounted)
- MIL-STD 167 – Vibration
- MIL-STD 461 – EMI
- MIL-STD 1399 – Magnetic Field (DC Magnetic Exposure)
- MIL-STD 810 – Temperature and Humidity

#### Universal Power Supply Options

- Fully integrated, dual-redundant (optional) power supplies
- Universal high-voltage range: 88-300VDC or 85-264VAC
- Popular low voltage DC ranges: 12, 24 or 48 VDC
- Terminal blocks for reliable maintenance free connections
- CSA/UL 60950 safety approved to +85°C

### **Simple Plug and Play Operation**

- Automatic learning of up to 8192 MAC addresses
- Auto-negotiation on all 10/100/1000BaseTX ports
- Auto-MDI/MDIX (crossover) on all 10/100BaseTX ports
- LED indicators for link, activity and speed

### **Rugged Operating System (ROS™) Advanced Network Management**

- Enhanced Rapid Spanning Tree (eRSTP™)
- Quality of Service (802.1p) for real-time traffic
- Port rate limiting: 128kbps - 8Mbps
- VLAN (802.1q) with double tagging
- IGMP Snooping for multicast filtering
- Port configuration, status, statistics, mirroring, security
- Loss of link management on fiber ports
- Web-based, Telnet, CLI management interfaces
- SNMP v2 and RMON
- Rich set of diagnostics with logging and alarms

## 4.2 Ethernet Panel Description

Each Ethernet module is equipped with two LEDs that indicate link/activity status information. The LED will be solid for ports with link, and will blink for activity. The diagram in Figure 1 highlights the port and the associated link/activity LED.

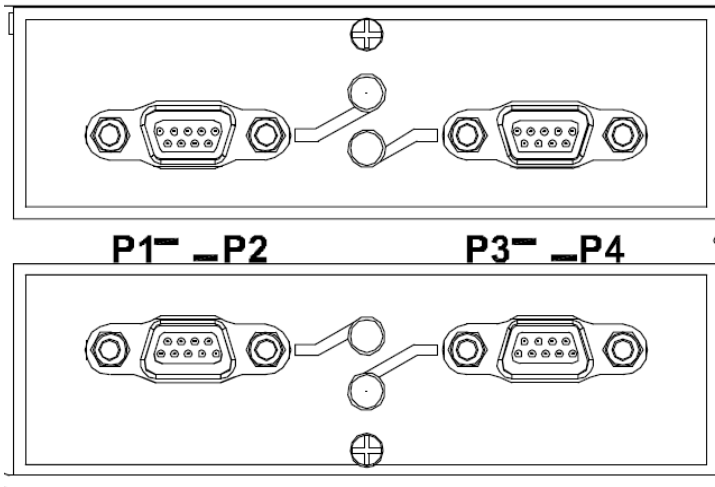

Figure 1: Ethernet panel LED description

## 4.2.1 Fiber Optic Transceiver Orientation and Connection

Depending on the order code of the product, the M2000 series products can be equipped with different types of fiber optic ports. The Transmit (TX) and Receive (RX) connections of each port must be properly connected and matched for proper link and operation. Modules populated on the top row of the device typically have locking mechanisms or tabs towards the top of the unit. Modules located on the bottom row of the device have locking mechanisms or tabs towards the bottom of the device.

The drawings in the following figures show each fiber optic connector style with a side and top view to allow the user to identify the proper cable connection orientation. If modules are populated on the bottom row of the device, the transceiver orientation will be reversed (i.e. RX and TX will be reversed).

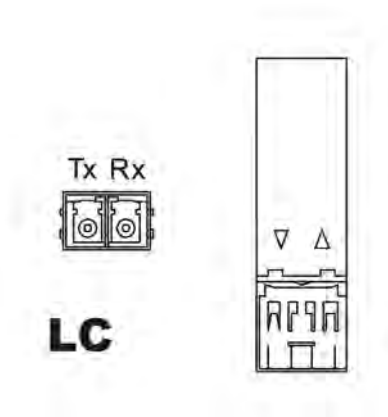

Figure 2: 1000BaseX LC connector

### 4.3 Display Panel Description

The M2000 series products are equipped with a versatile display panel, shown in Figure 3, which is designed to provide quick status information for each port, as well as the entire device to allow for simple diagnostics and troubleshooting. It features:

- RS232 console port for 'out of band' console access and configuration
- Power supply and Alarm status indicators
- Convenient port status indicators conveying Link-Activity, Duplex, or Speed via push-button control.
- System reset via push-button if held for 5 seconds

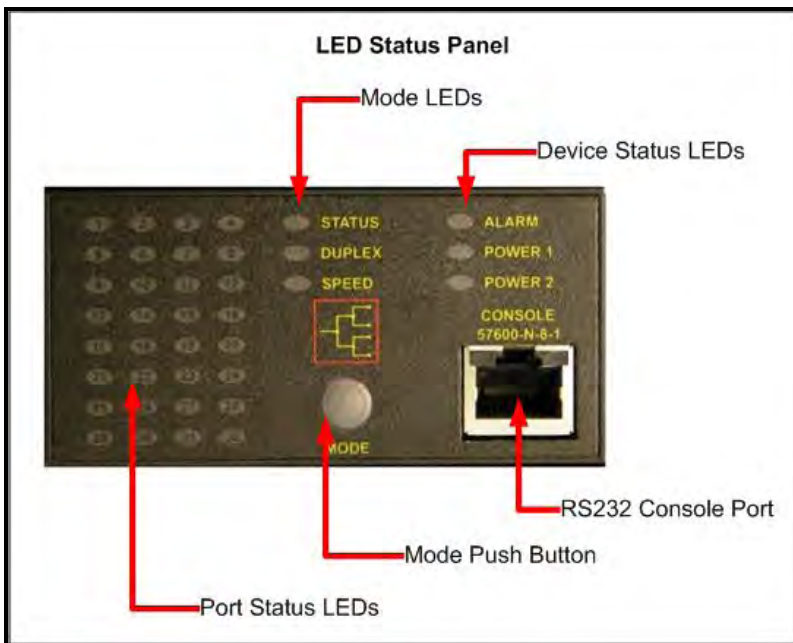

Figure 3: M2000 Series LED Display Panel

Device status LEDs exist to provide a quick visual indicator to operators for operational status of the unit. Table 1 defines the possible LED colours and the corresponding description.

| <i>LED</i> | <i>Colour</i> | <i>Description</i>  |
|------------|---------------|---|
| PS1 / PS2  | Green         | Power supply operating normal   |
|            | Red           | Power supply failure  |
|            | Off           | No power supply installed   |
| Alarm      | Red           | Alarm exist – login to web management interface to determine alarm code |
|            | Off           | No alarms exist   |

Table 1: LED Display – Device status LED behavior definition

The port-based LEDs can be cycled between three display modes: Status, Duplex, and Speed. Pushing the mode button causes the display mode to be cycled.

| <i>Mode</i> | <i>Colour</i>    | <i>Description</i>    |
|-------------|------------------|-----------------------|
| Status      | Green (Solid)    | Link                  |
|             | Green (Blinking) | Activity              |
|             | Off              | No link               |
| Duplex      | Green (Solid)    | Full-Duplex operation |
|             | Orange (Solid)   | Half-Duplex operation |
|             | Off              | No link               |
| Speed       | Green (Blinking) | 1000Mb/s              |
|             | Green (Solid)    | 100Mb/s               |
|             | Orange (Solid)   | 10Mb/s                |
|             | Off              | No link               |

Table 2: LED Display Description

## 5 Installation

### 5.1 Panel Mounting

The M2000 series products can be ordered with Panel mount chassis. This option involves the use of the panel adapters to be mounted on each side of the chassis enclosure. See Figure 4 for a Panel mount diagram.

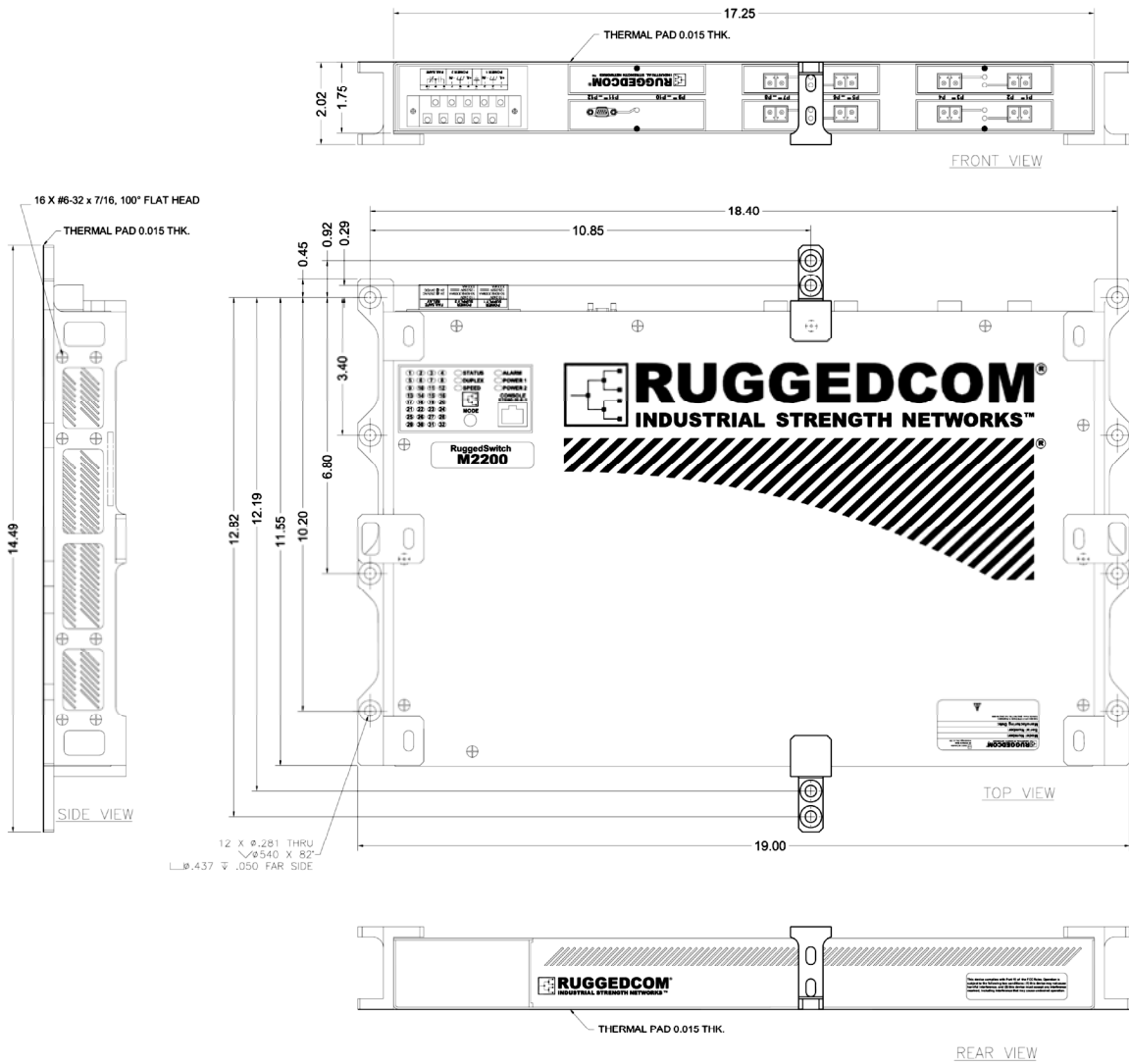

Figure 4: M2200 Panel Mounting Diagram

## 5.2 Power Supply Wiring and Grounding

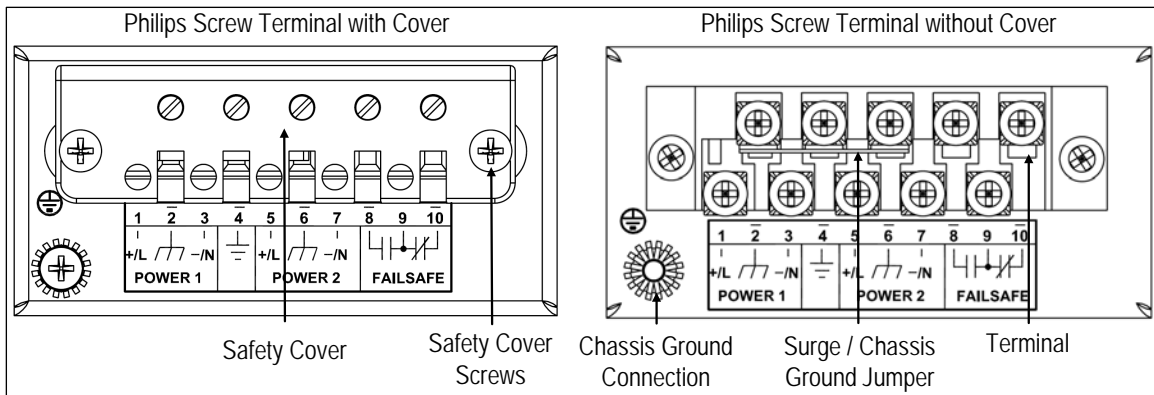

Figure 5: M2000 Series Phillips Screw Terminal Block

The M2000 Family supports dual redundant power supplies – “Power Supply 1 (PS1)” and “Power Supply 2 (PS2)”. The connections for PS1, PS2 and the fail-safe relay are located on the terminal block as shown in Figure 5.

The M2000 Family chassis ground connection, shown in Figure 6, uses a #6-32 screw. It is recommended to terminate the ground connection in a #6 ring lug, and to use a torque setting not exceeding 15 in.lbs (1.7 Nm).

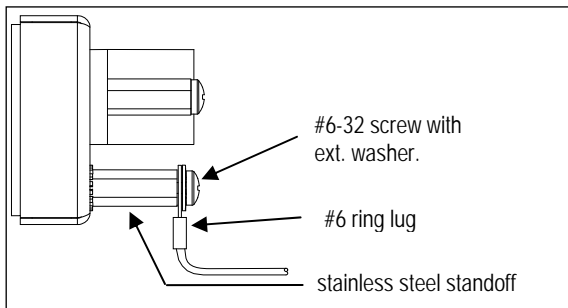

Figure 6: Chassis Ground Connection

The M2000 Family is equipped with a Phillips Screw Terminal Block. The Phillips Screw Terminal Block has Phillips screws with a compression plate allowing either bare wire connections or crimped terminal lugs. RuggedCom recommend the use of #6 size ring lugs to ensure secure, reliable connections under severe shock or vibration. The terminal block has a safety cover which must be removed via two Phillips screws before connecting any wires. The safety cover must be re-attached after wiring to ensure personnel safety. Refer to Table 3 below for a description of each terminal as well as sections 5.2.1 through 5.2.3 for wiring examples.

| <i>Terminal #</i> | <i>Description</i> | <i>Usage</i>  |
|-------------------|--------------------|---|
| 1                 | PS1 Live / +       | <b>PS1 Live / +</b> is connected to the positive (+) terminal if the power source is DC or to the (Live) terminal if the power source is AC.  |
| 2                 | PS1 Surge Ground   | <b>PS1 Surge Ground</b> is connected to the Chassis Ground via a jumper on the terminal block. Surge Ground is used as the ground conductor for all surge and transient suppression circuitry. <b>NOTE:</b> Surge Ground must be disconnected from Chassis Ground during HIPOT (dielectric strength) testing. |
| 3                 | PS1 Neutral / -    | <b>PS1 Neutral / -</b> is connected to the negative (-) terminal if the power source is DC or to the (Neutral) terminal if the power source is AC.  |
| 4                 | Chassis Ground     | <b>Chassis Ground</b> is connected to the Safety Ground terminal for AC inputs or the equipment ground bus for DC inputs. Chassis ground connects to both power supply surge grounds via a removable jumper.  |
| 5                 | PS2 Live / +       | <b>PS2 Live / +</b> is connected to the positive (+) terminal if the power source is DC or to the (Live) terminal if the power source is AC.  |
| 6                 | PS2 Surge Ground   | <b>PS2 Surge Ground</b> is connected to the Chassis Ground via a jumper on the terminal block. Surge Ground is used as the ground conductor for all surge and transient suppression circuitry. <b>NOTE:</b> Surge Ground must be disconnected from Chassis Ground during HIPOT (dielectric strength) testing. |
| 7                 | PS2 Neutral / -    | <b>PS2 Neutral / -</b> is connected to the negative (-) terminal if the power source is DC or to the (Neutral) terminal if the power source is AC.  |
| 8                 | Relay NO Contact   | Normally open, failsafe relay contact.  |
| 9                 | Relay Common       | Failsafe relay common contact.  |
| 10                | Relay NC Contact   | Normally closed, failsafe relay contact.  |

Table 3: M2200 Power terminal block connection description

## 5.2.1 AC Power Supply Wiring Examples

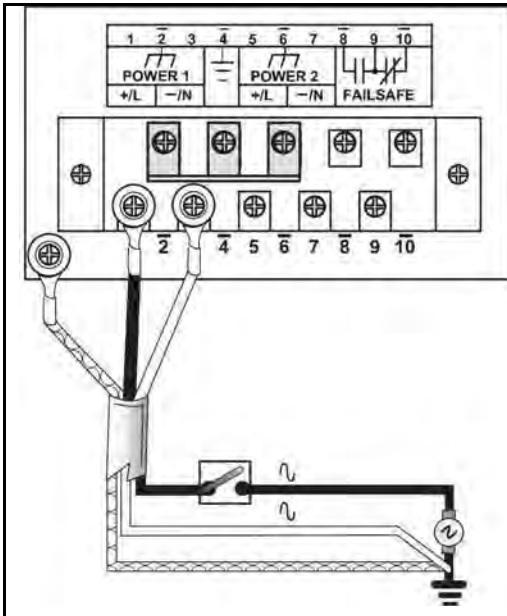

Figure 7: AC Single Power Supply Wiring Example

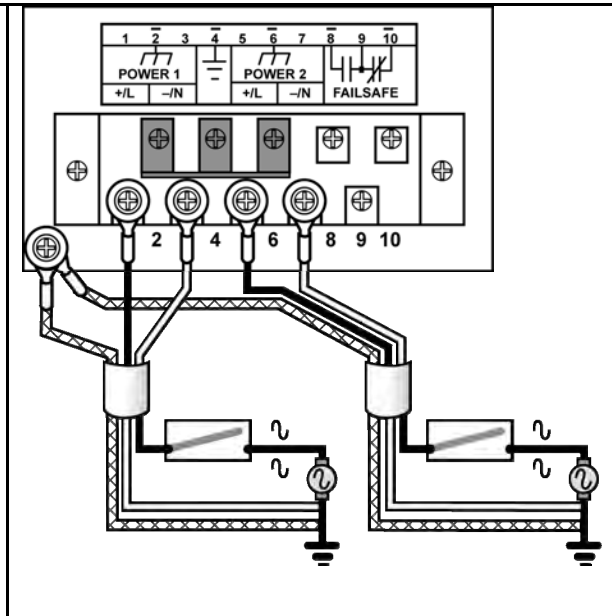

Figure 8: AC Dual Redundant Power Supply Wiring Example

### NOTES:

1. 100-240VAC rated equipment: A 250VAC appropriately rated circuit breaker must be installed.
2. Equipment must be installed according to the applicable country wiring codes.
3. When equipped with two HI voltage power supplies, independent AC sources can be used to power the product for greater redundancy.

## 5.2.2 DC Power Supply Wiring Examples

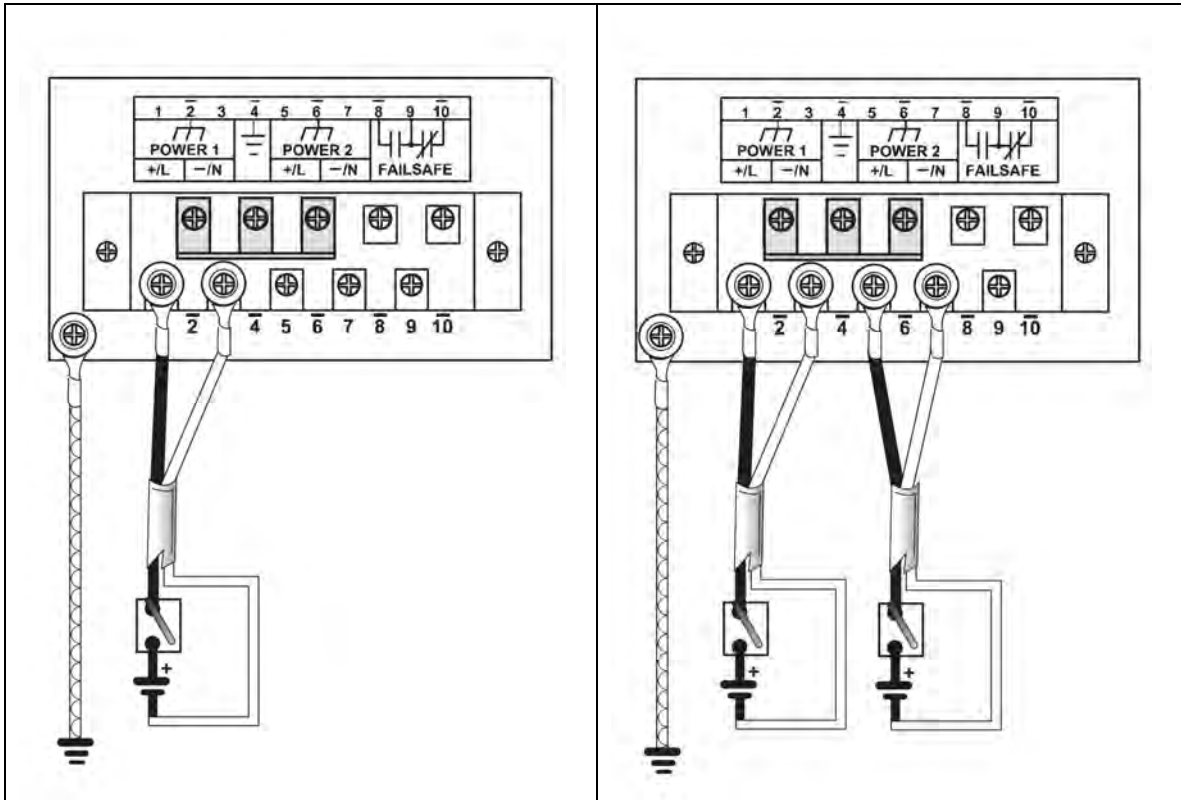

Figure 9: DC Power Supply Wiring Examples

### NOTES:

1. 88-300VDC rated equipment: A 300VDC appropriately rated circuit breaker must be installed.
2. A circuit breaker is not required for 12, 24 or 48 VDC rated power supplies.
3. For dual DC power supplies, Separate circuit breakers must be installed and separately identified.
4. Equipment must be installed according to the applicable country wiring codes.

### 5.2.3 Dual Power Supplies – DC and AC Inputs

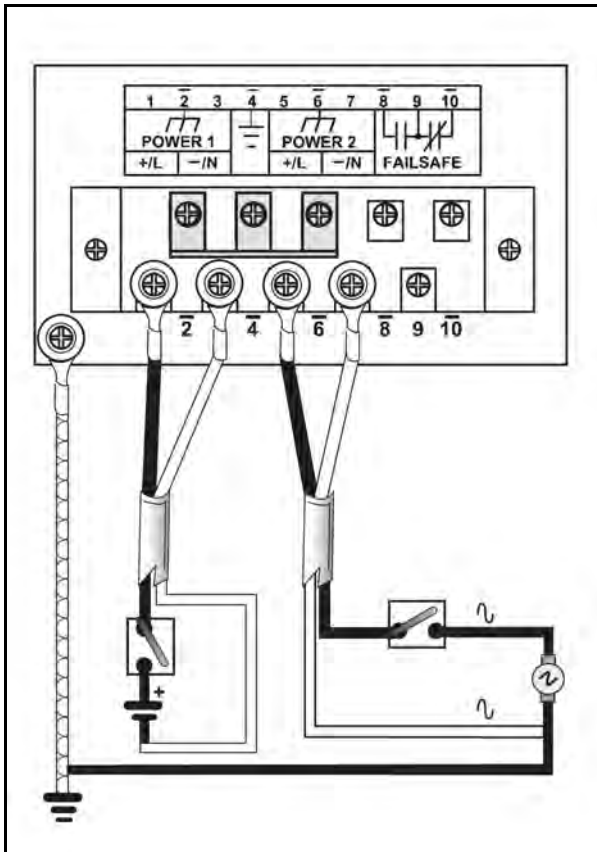

Figure 10: DC and AC Power Supply Wiring Examples

**NOTES:**

1. 88-300VDC rated equipment: A 300VDC appropriately rated circuit breaker must be installed.
2. 100-240VAC rated equipment: A 250VAC appropriately rated circuit breaker must be installed.
3. A circuit breaker is not required for 48 or 24VDC rated power supplies.
4. Separate circuit breakers must be installed and separately identified.
5. Equipment must be installed according to the applicable country wiring codes.

### 5.3 Dielectric Strength (HIPOT) Testing

For dielectric strength (HIPOT) testing in the field, users must remove the metal jumper located on terminal 2, 4, and 6 of the power supply terminal block. This metal jumper connects transient suppression circuitry to chassis ground and must be removed in order to avoid damage to transient suppression circuitry during HIPOT testing. Figure 11 shows the proper HIPOT test connections and should be followed to avoid damage to the device.

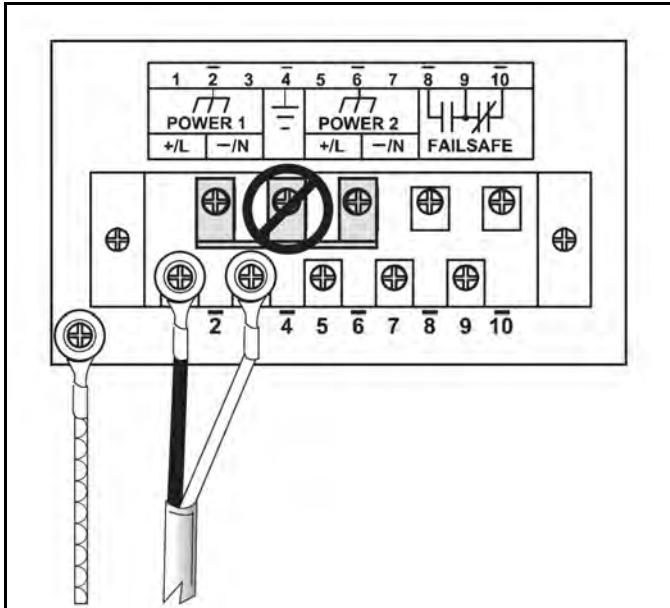

Figure 11: Dielectric Strength (HIPOT) Testing

### 5.4 Failsafe Alarm Relay Wiring and Specifications

The “Failsafe” output relay is provided to signal critical error conditions that may occur on the M2000 series products. The contacts are energized upon power up of the unit and remain energized until a critical error occurs. The proper relay connections are shown in Figure 12. One common application for this output is to signal an alarm if a power failure or removal of control power occurs.

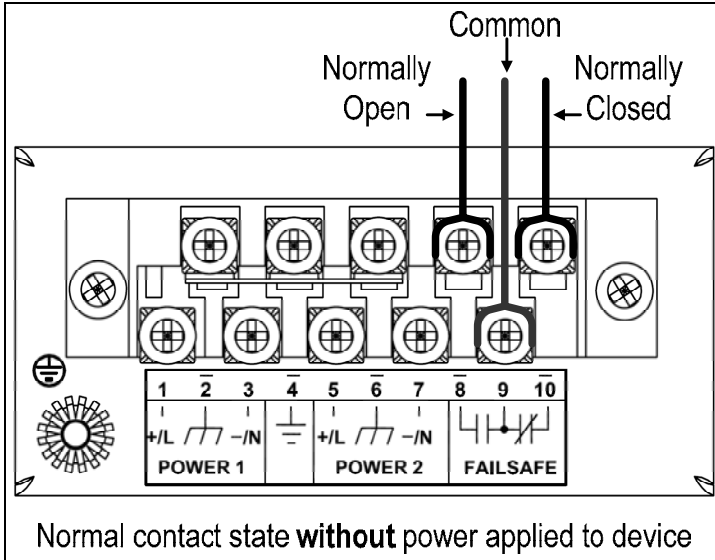

Figure 12: Failsafe Alarm Relay Wiring

## 5.5 Console Port Wiring

A RS232 console port for configuration and management of the device is located on the LED display module shown in Figure 13. This port is intended to be a temporary connection during initial configuration or troubleshooting and allows for direct access to the serial-based management console. The connection is made using the DB9-Female to RJ45 console cable included in the device packaging shown in Figure 14. Console connection settings are: 57600 baud, no parity bits, 8 data bits, and 1 stop bit.

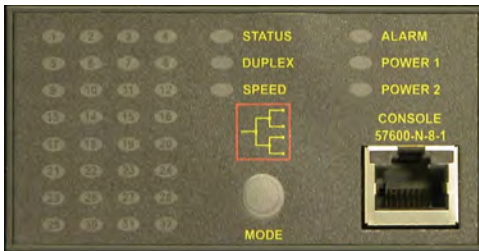

Figure 13: Console port location on display board



Figure 14: M2200 Console cable

For user reference, the console cable pin-out is shown in Table 4.

| <i>RuggedCom RS232 over RJ45 pin-out specification</i> |                    |                  |
|--|--------------------|------------------|
| <i>Signal Name (PC is DTE)</i>                         | <i>DB9- Female</i> | <i>RJ45 Male</i> |
| DCD – Carrier detect                                   | 1                  | 2                |
| RxD – Receive data (to DTE)                            | 2                  | 5                |
| TxD – Transmit data (from DTE)                         | 3                  | 6                |
| DTR – Data terminal ready                              | 4                  | 3                |
| Signal GND   | 5                  | 4                |
| DSR – Data set ready                                   | 6                  | 1*               |
| RTS – Ready to send                                    | 7                  | 8                |
| CTS – Clear to send                                    | 8                  | 7                |
| RI – Ring Indicator                                    | 9                  | 1*               |

Table 4: RS232 over RJ45 console cable pin-out

After initial configuration, the RuggedSwitch device can be configured via a number of new mechanisms such as Telnet, and the built-in web server. Consult the RuggedSwitch ROS User Guide for further details.

**NOTE:** This port is not intended to be a permanent connection and the cable shall be less than 2m (6.5 ft) in length.

## 5.6 Twisted-Pair Data Ports

### 5.6.1 Micro-D Twisted-Pair Data Ports

The M2100 may have several 10/100/1000BaseTX ports that allow connection to standard CAT-5 UTP cable with Micro-D connectors. Figure 15 shows the Micro-D port pin configuration.

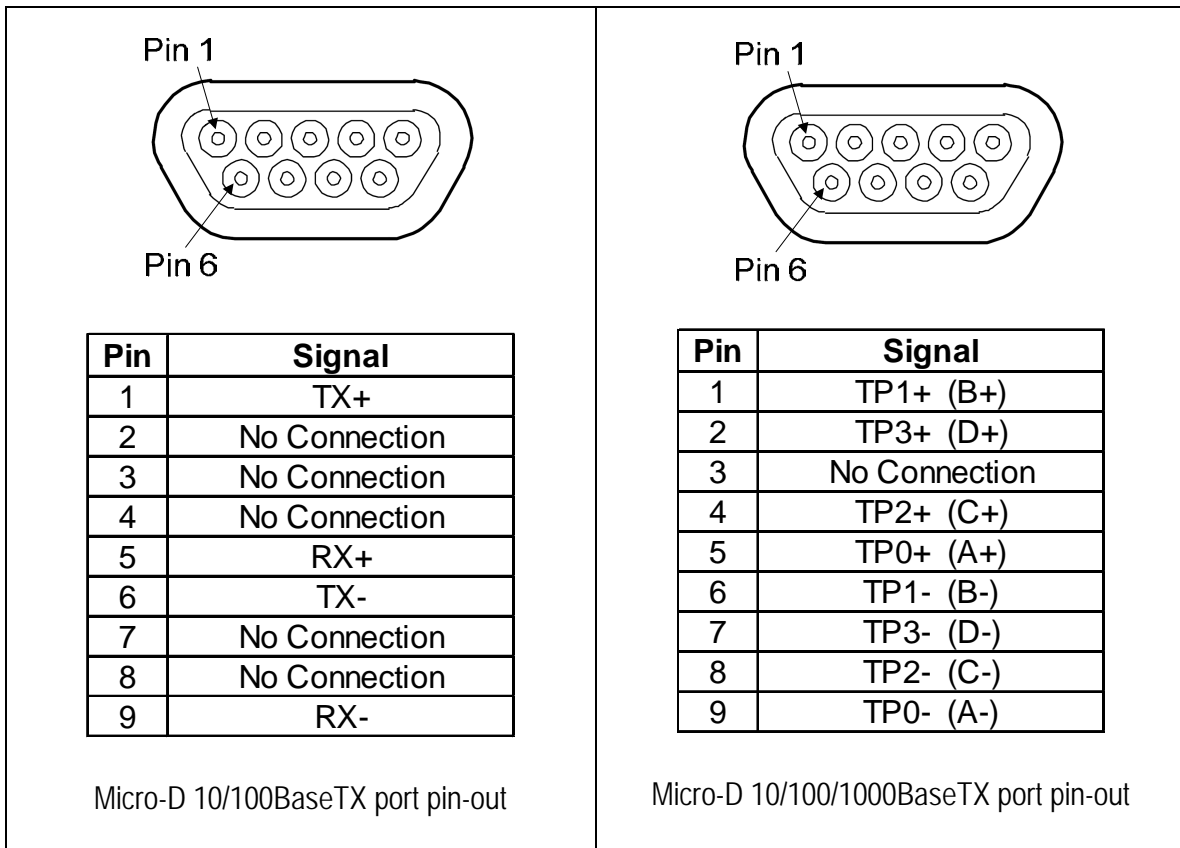

Figure 15: Micro-D port pin configuration

#### NOTES:

1. For 10/100Base-TX ports: pin2 and pin7 are internally connected, pin4 and pin8 are internally connected on PCB board.
2. For 10/100/1000Base-TX ports: pin3 and pin8 are internally connected on PCB board.

## 5.6.2 Protection on Twisted-Pair Data Ports

RuggedCom does not recommend the use of CAT-5 cabling of any length for critical real-time substation automation applications. However, transient suppression circuitry is present on all copper ports to protect against damage from electrical transients and to ensure IEC 61850-3 and IEEE 1613 Class 1 conformance. This means that during the transient event communications errors or interruptions may occur but recovery is automatic.

RuggedCom also does not recommended to use these ports to interface to field devices across distances which could produce high levels of ground potential rise, (i.e. greater than 2500V) during line to ground fault conditions.

## 5.7 Gigabit Ethernet 1000Base-Tx Cabling Recommendations

The IEEE 802.3ab Gigabit Ethernet standard defines 1000Mbit/s Ethernet communications over distances of up to 100 meters using 4 pairs of category 5 (or higher) balanced unshielded twisted-pair cabling. For wiring guidelines, system designers and integrators should refer to the Telecommunications Industry Association (TIA) TIA/EIA-568-A wiring standard that characterizes minimum cabling performance specifications required for proper Gigabit Ethernet operation. To ensure reliable, error-free data communications, new and pre-existing communication paths should be verified for TIA/EIA-568-A compliance. Table 5 summarizes cabling standards available today.

| <i>Cabling Category</i> | <i>1000BaseTx Compliant</i> | <i>Required action</i>   |
|-------------------------|-----------------------------|--|
| < 5                     | No                          | New wire infrastructure required   |
| 5                       | Yes                         | Verify TIA/EIA-568-A compliance  |
| 5e                      | Yes                         | No action required. New installations should be designed with Category 5e components or higher |
| 6                       | Yes                         | No action required   |
| > 6                     | Yes                         | Connector and cabling standards to be determined.  |

Table 5: Cabling categories and 1000BaseTx compliance defined.

In general the following recommendations should be followed for copper data cabling in high electrical noise environments:

- Data cable lengths should be as short as possible, ideally limited to 3m (10ft) in length. Copper data cables should not be used for inter-building communications.
- Power and data cables should not be run in parallel for long distances, and ideally should be installed in separate conduits. Power and data cables should intersect at 90° angles when necessary to reduce inductive coupling.
- Shielded/screened cabling can optionally be used. The cable shield should be grounded at one single point to avoid the generation of ground loops.

## 6 Technical Specifications

### 6.1 Power Supply Specifications

| Power Supply Type  | Input Range      |                    | Internal Fuse Rating  | Max. Power Consumption <sup>3</sup> |
|--|------------------|--------------------|-----------------------|-------------------------------------|
|  | Min              | Max                |                       |                                     |
| 12 – 24 VDC  | 10 VDC           | 36 VDC             | 6.3A(F) <sup>2</sup>  | 22W                                 |
| 48 VDC   | 36 VDC           | 72 VDC             | 3.15A(T) <sup>2</sup> |                                     |
| HI (125/250 VDC) <sup>1</sup><br>HI (110/230 VAC) <sup>1</sup> | 88 VDC<br>85 VAC | 300 VDC<br>264 VAC | 2A(T) <sup>1,2</sup>  |                                     |

**NOTES:**

1. This is the same power supply for both AC and DC.
2. (F) Denotes fast-acting fuse, (T) denotes time-delay fuse
3. Power consumption varies based on configuration. 10/100Tx ports consume roughly 1W less than fiber optic ports.

### 6.2 Failsafe Relay Specifications

| Parameter               | Value (Resistive Load)                    |
|-------------------------|---|
| Max Switching Voltage   | 240VAC, 125VDC                            |
| Rated Switching Current | 2A @ 240VAC<br>0.15A @ 125VDC, 2A @ 30VDC |
| Max Switching Capacity  | 150W, 500VA                               |

### 6.3 Networking Standards Supported

| <i>Parameter</i> | <i>10Mbps Ports</i> | <i>100Mbps Ports</i> | <i>1000Mbps Ports</i> | <i>Notes</i>          |
|------------------|---------------------|----------------------|-----------------------|-----------------------|
| IEEE 802.3       |                     |                      |                       | 10BaseT / 10BaseFL    |
| IEEE 802.3u      |                     |                      |                       | 100BaseTX / 100BaseFX |
| IEEE 802.3z      |                     |                      | ✓                     | 1000BaseSX/LX         |
| IEEE 802.3ab     |                     |                      | ✓                     | 1000BaseTx            |
| IEEE 802.3x      | ✓                   | ✓                    | ✓                     | Full Duplex Operation |
| IEEE 802.1D      | ✓                   | ✓                    | ✓                     | MAC Bridges           |
| IEEE 802.1Q      | ✓                   | ✓                    | ✓                     | VLAN (Virtual LAN)    |
| IEEE 802.1p      | ✓                   | ✓                    | ✓                     | Priority Levels       |

### 6.4 Twisted-Pair Port Specifications

| <i>Parameter</i> | <i>Specification</i> | <i>Notes</i>                  |
|------------------|----------------------|-------------------------------|
| Speed            | 10/100 Mbps          | Auto-negotiating              |
| Duplex           | FDX / HDX            | Auto-negotiating              |
| Cable-Type       | > Category 5         | Shielded/Unshielded           |
| Wiring Standard  | TIA/EIA T568A/B      | Auto-Crossover, Auto-polarity |
| Max Distance     | 100m                 |                               |
| Connector        | RJ45                 |                               |
| Isolation        | 1.5kV                | RMS 1-minute                  |

## 6.5 Fiber Optic Specifications

The following sections detail fiber optic specifications on ports that can be ordered with the M2200 series Ethernet switch. The user determines the type of optics at time of ordering, and can determine the modules installed on a particular unit by reading the factory data file via the RuggedSwitch ROST™ user interface. The following sections detail specifications of fiber optic modules in Gigabit Ethernet (1000Mbps).

### 6.5.1 Gigabit Ethernet (1000Mbps) Modules

For maximum flexibility RuggedCom Inc. offers a number of different transceiver choices for Gigabit fiber optic communications. The following table details fiber optic specifications based on the 2-port modules or pluggable transceivers selected at time of ordering.

| <i>Optics Order Code</i> | <i>Mode / Connector</i> | <i>Tx λ (nm)</i> | <i>Cable Type<sup>2</sup></i> | <i>Tx Pwr (dBm)<sup>3</sup> (Min/Max)</i> | <i>Rx Sensitivity (dBm)<sup>3</sup></i> | <i>Rx Saturation (dBm)<sup>3</sup></i> | <i>Typical Distance (km)<sup>1</sup></i> | <i>Power Budget (dB)</i> |
|--------------------------|-------------------------|------------------|-------------------------------|---|---|--|--|--------------------------|
| 12-11-0036               | MM / LC                 | 850              | 50μ/125                       | -9.5 / -4                                 | -20                                     | 0                                      | 0.5                                      | 13                       |
| 12-11-0027               | SM / LC                 | 1310             | 9μ/125                        | -9.5 / -3                                 | -22                                     | -3                                     | 10                                       | 18.5                     |
| 12-11-0028               | SM / LC                 | 1310             | 9μ/125                        | -5 / 0                                    | -22                                     | -3                                     | 25                                       | 19.5                     |

**NOTES:**

1. Maximum segment length is greatly dependent on factors such as fiber quality, and number of patches and splices. Please consult RuggedCom sales associates when determining maximum segment distances.
2. All cabling is duplex type unless otherwise specified.
3. All optical power numbers are listed as dBm averages.
4. These transceivers utilize a distributed feedback (DFB) type laser and are rated for -20°C to +85°C operation only.

## 6.6 Operating Environment

| <i>Parameter</i>              | <i>Range</i> | <i>Comments</i>   |
|-------------------------------|--------------|---|
| Ambient Operating Temperature | -40 to 85°C  | Ambient Temperature as measured from a 30cm radius surrounding the center of the enclosure. |
| Ambient Relative Humidity     | 5% to 95%    | Non-condensing  |
| Ambient Storage Temperature   | -40 to 85°C  |   |

### 6.7 Mechanical Specifications

| Parameter  | Value  | Comments  |
|------------|--|---|
| Dimensions | 19.00 x 14.50 x 2.02 inches<br>(482.6) x (368.3) x (51.3) mm | (Length x Width x Height)<br>with mounting brackets installed |
| Weight     | 11.2 lb (5 Kg)   | with mounting brackets installed                              |
| Enclosure  | 18awg galvanized steel                                       |   |

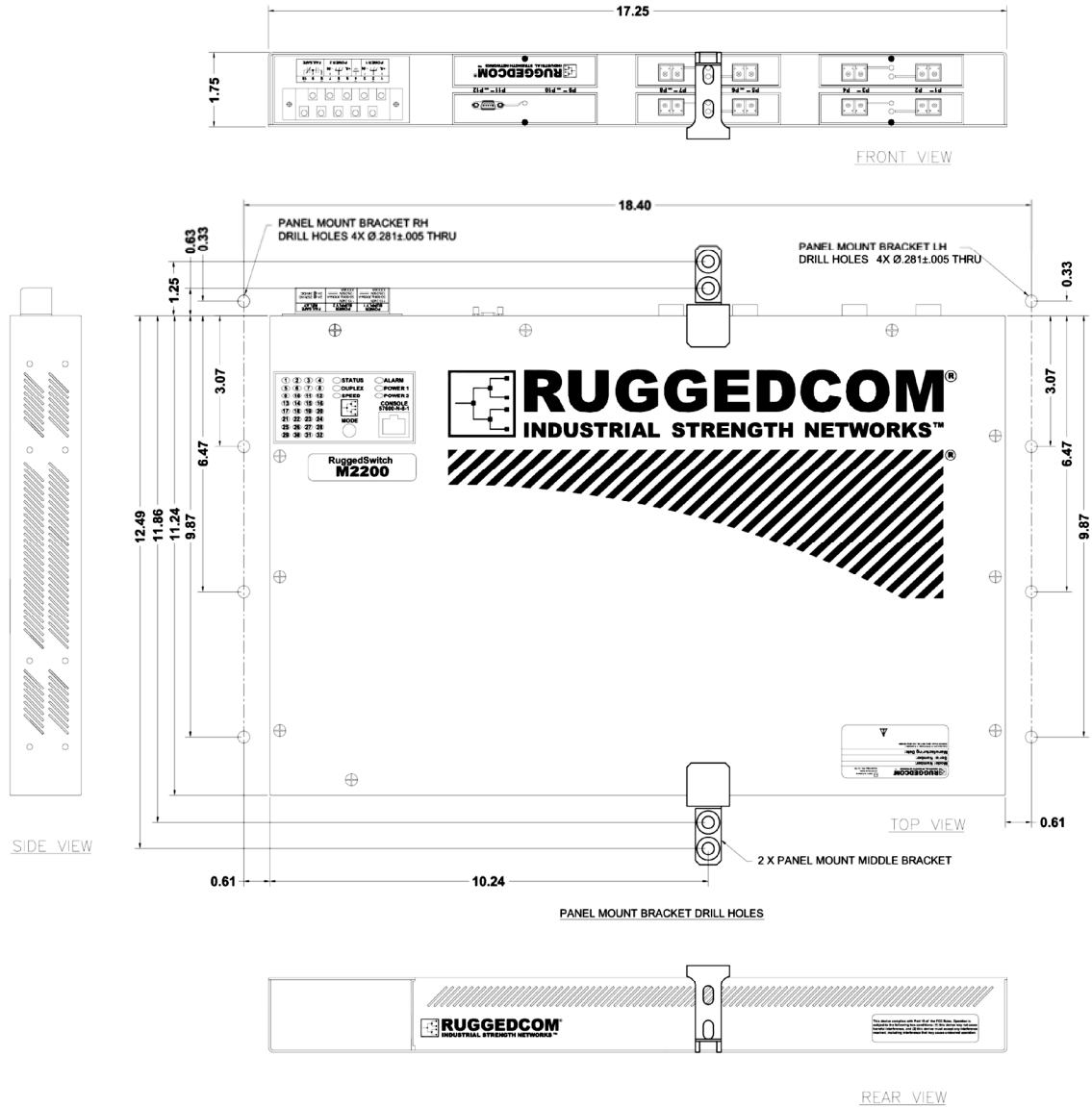

Figure 16: Mechanical Dimensions

## 7 Type Tests

### 7.1 IEC 61850-3 Type Tests

| Test           | Description                 |                    | Test Levels  | Severity Levels |
|----------------|-----------------------------|--------------------|--|-----------------|
| IEC 61000-4-2  | ESD                         | Enclosure Contact  | +/- 8kV  | 4               |
|                |                             | Enclosure Air      | +/- 15kV   | 4               |
| IEC 61000-4-3  | Radiated RFI                | Enclosure ports    | 20 V/m   | x               |
| IEC 61000-4-4  | Burst (Fast Transient)      | Signal ports       | +/- 4kV @ 2.5kHz                                     | x               |
|                |                             | D.C. Power ports   | +/- 4kV  | 4               |
|                |                             | A.C. Power ports   | +/- 4kV  | 4               |
|                |                             | Earth ground ports | +/- 4kV  | 4               |
| IEC 61000-4-5  | Surge                       | Signal ports       | +/- 4kV line-to-earth, +/- 2kV line-to-line          | 4               |
|                |                             | D.C. Power ports   | +/- 2kV line-to-earth, +/- 1kV line-to-line          | 3               |
|                |                             | A.C. Power ports   | +/- 4kV line-to-earth, +/- 2kV line-to-line          | 4               |
| IEC 61000-4-6  | Induced (Conducted) RFI     | Signal ports       | 10V  | 3               |
|                |                             | D.C Power ports    | 10V  | 3               |
|                |                             | A.C. Power ports   | 10V  | 3               |
|                |                             | Earth ground ports | 10V  | 3               |
| IEC 61000-4-8  | Magnetic Field              | Enclosure ports    | 40 A/m continuous, 1000 A/m for 1 s                  | N/A             |
| IEC 61000-4-29 | Voltage Dips & Interrupts   | D.C. Power ports   | 30% for 0.1s, 60% for 0.1s, 100% for 0.05s           | N/A             |
| IEC 61000-4-11 |                             | A.C. Power ports   | 30% for 1 period, 60% for 50 periods                 | N/A             |
| IEC 61000-4-12 | Damped Oscillatory          | Signal ports       | 100% for 5 periods, 100% for 50 periods <sup>2</sup> | N/A             |
|                |                             | D.C. Power ports   | 2.5kV common, 1kV differential mode @ 1MHz           | 3               |
|                |                             | A.C. Power ports   | 2.5kV common, 1kV differential mode @ 1MHz           | 3               |
| IEC 61000-4-16 | Mains Frequency Voltage     | Signal ports       | 30V Continuous, 300V for 1s                          | 4               |
|                |                             | D.C. Power ports   | 30V Continuous, 300V for 1s                          | 4               |
| IEC 61000-4-17 | Ripple on D.C. Power Supply | D.C. Power ports   | 10%  | 3               |
| IEC 60255-5    | Dielectric Strength         | Signal ports       | 2kV AC (Fail-Safe Relay output)                      | N/A             |
|                |                             | D.C. Power ports   | 1.5kVDC  | N/A             |
|                |                             | A.C. Power ports   | 2kVAC  | N/A             |
| IEC 60255-5    | H.V. Impulse                | Signal ports       | 5kV (Fail-Safe Relay output)                         | N/A             |
|                |                             | D.C. Power ports   | 5kV  | N/A             |
|                |                             | A.C. Power ports   | 5kV  | N/A             |

Table 6 - IEC 61850-3 Type Tests

### 7.2 IEEE 1613 Type Tests

| IEEE Test | IEEE 1613 Clause | Description | Test Levels |
|-----------|------------------|-------------|-------------|
|-----------|------------------|-------------|-------------|

|          |   |                     |                    |   |
|----------|---|---------------------|--------------------|---|
| C37.90.3 | 9 | ESD                 | Enclosure Contact  | +/- 8kV                                 |
|          |   |                     | Enclosure Air      | +/- 15kV                                |
| C37.90.2 | 8 | Radiated RFI        | Enclosure ports    | 35 V/m                                  |
| C37.90.1 | 7 | Fast Transient      | Signal ports       | +/- 4kV @ 2.5kHz                        |
|          |   |                     | D.C. Power ports   | +/- 4kV                                 |
|          |   |                     | A.C. Power ports   | +/- 4kV                                 |
|          |   |                     | Earth ground ports | +/- 4kV                                 |
| C37.90.1 | 7 | Oscillatory         | Signal ports       | 2.5kV common mode @ 1MHz                |
|          |   |                     | D.C. Power ports   | 2.5kV common & differential mode @ 1MHz |
|          |   |                     | A.C. Power ports   | 2.5kV common & differential mode @ 1MHz |
| C37.90   | 6 | H.V. Impulse        | Signal ports       | 5 kV (Failsafe Relay)                   |
|          |   |                     | D.C. Power ports   | 5 kV                                    |
|          |   |                     | A.C. Power ports   | 5 kV                                    |
| C37.90   | 6 | Dielectric Strength | Signal ports       | 2kVAC                                   |
|          |   |                     | D.C. Power ports   | 1.5kVDC                                 |
|          |   |                     | A.C. Power ports   | 2kVAC                                   |

Table 7 - IEEE 1613 Type Tests

### 7.3 Military Standard Tests

| <i>Test</i>     | <i>Description</i>                        | <i>Test Levels</i>   |
|-----------------|---|--|
| MIL-STD-901D *  | Shock (Hard-Mounted)                      | Grade A, Equipment Class I, Shock Type A Equipment                   |
| MIL-STD-167-1 * | Vibration                                 | Type I (Upper Frequency of 33 Hz)                                    |
| MIL-STD-461E *  | Electromagnetic Interference              | CE101, CE102, CS101, CS114, CS115, CS116, RE101, RE102, RS101, RS103 |
| MIL-STD-1399 *  | Magnetic Field - DC Magnetic Exposure     | Section 070, Part 1  |
| MIL-STD-810F *  | Temperature - Low/High Temperature        | Method 501   |
| MIL-STD-810 *   | Temperature - Non-operating Thermal Shock | Method 503   |
| MIL-STD-810 *   | Humidity                                  | Method 507, Procedure IV   |

Table 8 – Military Standard Tests

\* Testing complete, pending final documentation (contact RuggedCom for complete details)

## 8 Agency Approvals

| <i>Agency</i> | <i>Standards</i>                    | <i>Comments</i>   |
|---------------|-------------------------------------|---|
| CE            | EN 60950, EN 61000-6-2              | CE Compliance is claimed via Declaration of Self Conformity Route |
| FCC           | FCC Part 15, Class A                | Passed  |
| CISPR         | EN55022, Class A                    | Passed  |
| FDA/CDRH      | 21 CFR Chapter 1, Subchapter J      | Passed  |
| IEC/EN        | EN60825-1:1994 + A11:1996 + A2:2001 | Passed  |

## 9 Warranty

RuggedCom warrants this product for a period of five (5) years from date of purchase. For warranty details, visit <http://www.ruggedcom.com/> or contact your customer service representative.

Should this product require warranty or service contact the factory at:

RuggedCom Inc.  
300 Applewood Crescent  
Concord, Ontario  
Canada L4K 5C7

Phone: +1 905 856 5288  
Fax: +1 905 856 1995