

RuggedMC™ RMC20

Installation Guide

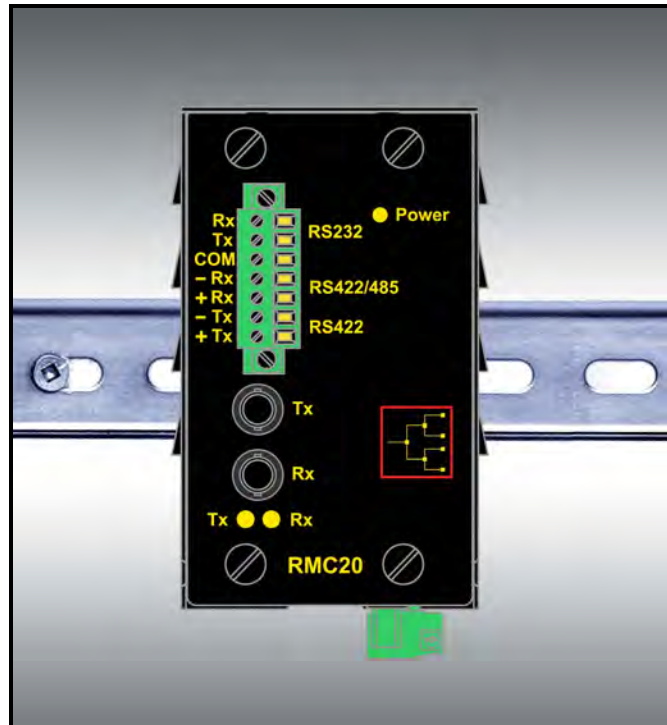

RuggedCom Inc.
300 Applewood Crescent
Concord, Ontario
Canada L4K 5C7

Web: <http://www.ruggedcom.com/>

Tel: +1 905 856 5288

Fax: +1 905 856 1995

Toll Free: 1 888 264 0006

Copyright

COPYRIGHT © 2010 RuggedCom Inc. ALL RIGHTS RESERVED

Dissemination or reproduction of this document, or evaluation and communication of its contents, is not authorized except where expressly permitted. Violations are liable for damages. All rights reserved, particularly for the purposes of patent application or trademark registration.

This document contains proprietary information, which is protected by copyright. All rights are reserved. No part of this document may be photocopied, reproduced or translated to another language without the prior written consent of RuggedCom Inc.

Disclaimer of liability

We have checked the contents of this manual against the hardware and software described. However, deviations from the description cannot be completely ruled out.

RuggedCom shall not be liable for any errors or omissions contained herein or for consequential damages in connection with the furnishing, performance, or use of this material.

The information given in this document is reviewed regularly and any necessary corrections will be included in subsequent editions. We appreciate any suggested improvements. We reserve the right to make technical improvements without notice.

Registered Trademarks

Rugged MediaConverter™, ROS™ and RuggedMC™ are trademarks of RuggedCom Inc. Other designations in this manual might be trademarks whose use by third parties for their own purposes would infringe the rights of the owner.

Contacting RuggedCom

Corporate Headquarters	US Headquarters	Europe Headquarters
RuggedCom Inc. 300 Applewood Crescent Concord, Ontario Canada, L4K 5C7	RuggedCom 1930 Harrison St., Suite 209 Hollywood, Florida USA, 33020	RuggedCom Unit 41, Aztec Centre, Aztec West, Almondsbury, Bristol United Kingdom BS32 4TD
Tel: +1 905 856 5288 Fax: +1 905 856 1995 Toll-free: 1 888 264 0006	Tel: +1 954 922 7938 ext. 103 Fax: +1 954 922 7984 Toll-free: 1 888 264 0006	Tel: +44 1454 203 404 Fax: +44 1454 203 403
Email: RuggedSales@RuggedCom.com		

Technical Support

Toll Free (North America): 1 866 922 7975
International: +1 905 856 5288
Email: Support@RuggedCom.com

Web: www.RuggedCom.com

Federal Communications Commission Radio Frequency Interference Statement

This equipment has been tested and found to comply with the limits for a Class A digital device pursuant to Part 15 of the FCC Rules. These limits are designed to provide reasonable protection against harmful interference when the equipment is operated in a commercial environment. This equipment generates, uses and can radiate radio frequency energy and, if not installed and used in accordance with the instruction manual, may cause harmful interference to radio communications. Operation of this equipment in a residential area is likely to cause harmful interference in which case the user will be required to correct the interference on his own expense.

Warning: Changes or modifications not expressly approved by RuggedCom Inc. could void the user's authority to operate the equipment.

Caution – This product contains a laser system and is classified as a
“CLASS 1 LASER PRODUCT”

Caution – Use of controls or adjustments or performance of procedures other than those specified herein may result in hazardous radiation exposure. This product contains no user-serviceable parts. Attempted service by unauthorized personnel shall render all warranties null and void.

Should this device require service see the “Warranty and Service” section of this installation guide.

Important:

The RuggedMC™ should be installed in a **restricted access location** where access can only be gained by service personnel or users who have been instructed about the reasons for the restrictions applied to the location and about any precautions that shall be taken; and access is through the use of a tool or lock and key, or other means of security, and is controlled by the authority responsible for the location.

Table of Contents

1	Product Overview	5
1.1	RMC20 Front Panel Description	6
1.2	RMC20 Side and Bottom View.....	7
2	Installation	8
2.1	DIN Rail Mounting.....	8
2.2	Panel Mounting.....	9
2.3	Power Supply Wiring and Grounding.....	10
2.4	Serial Ports – Signal Description	11
2.4.1	RS232 Data Ports	11
2.4.2	RS422 and RS485 Data Ports.....	12
2.5	RMC20 Configuration	14
2.5.1	Serial-to-Fiber Conversion: Point-to-Point.....	15
2.5.2	Serial Standard Conversion.....	16
2.5.3	Serial-to-Fiber Conversion: Loop Topology.....	17
3	Specifications	18
3.1	Power Supply Specifications.....	18
3.2	Fiber Optical Port Specifications.....	18
3.3	Mechanical Specifications	19
3.4	Operating Environment.....	20
4	Type Tests.....	21
4.1	IEC 61850-3 Type Tests.....	21
4.2	IEEE 1613 Type Tests.....	22
4.3	IEC Environmental Type Tests	22
5	Agency Approvals	23
6	Warranty.....	23

1 Product Overview

INTRODUCTION

The RuggedMC™ series of media converters are industrial hardened and specifically designed to operate reliably in electrically harsh and climatically demanding environments.

The RMC20 is a utility-grade, protocol-independent, serial-to-fiber and serial standards converter for all your serial communication requirements. The RMC20 allows RS485, RS422, or RS232 devices or networks to communicate over secure, noise immune, optically isolated, fiber optic cabling at extended distances as well convert RS232 to either RS485 or RS422 serial standards.

The RMC20 was designed specifically to provide years of maintenance free operation for all your mission-critical, real-time control applications. To ensure the utmost in reliability, the RMC20 is tested to the most stringent international EMI and environmental standards for use in HV/MV electric utility substations and factory floor applications. All RMC™ products are packaged with a high reliability, built-in power supply (24V, 48V, or HI Voltage options) and enclosed in a rugged galvanized steel enclosure suitable for panel or DIN-rail mounting.

All RuggedCom Inc. products are backed by a five-year warranty and unsurpassed technical support.

PORT OPTIONS

- Protocol independent RS485, RS422, or RS232 (user selectable) conversion to multimode fiber optics (ST connector only)
- RS232 to RS485/RS422 conversion mode
- Fully EIA/TIA RS485, RS422, RS232 compliant communications
- Built-in, defeatable, RS485/RS422 termination networks
- Point-to-point, or optical loop configurations
- Full or half duplex configurable
- Support for high-speed serial baud rates from 300 to 115200 baud

UNIVERSAL POWER SUPPLY OPTIONS

- 24VDC, 48VDC or HI (88-300VDC / 85 - 264Vac) options for worldwide operability
- Integrated high-reliability power supply eliminates the need for external power transformer
- Screw down terminal blocks ensure reliable maintenance-free connections
- All power supplies CSA/UL 60950 approved for +85°C (185°F) operation

DESIGNED FOR HARSH ENVIRONMENTS

- Exceeds IEC 61850-3 and IEEE 1613 Standards for communication equipment in electric power substations
- Operates over a temperature range of -40 C to +85 C without the use of fans for improved reliability
- 18 AWG galvanized steel enclosure suitable for DIN or panel mounting provide secure mechanical reliability

SIMPLE PLUG AND PLAY OPERATION

- Simple, externally-accessible configuration
- Transmit and receive data LED indicators for quick and easy troubleshooting
- Fully integrated power supply connects directly to power source permanently for reliable maintenance-free operation

1.1 RMC20 Front Panel Description

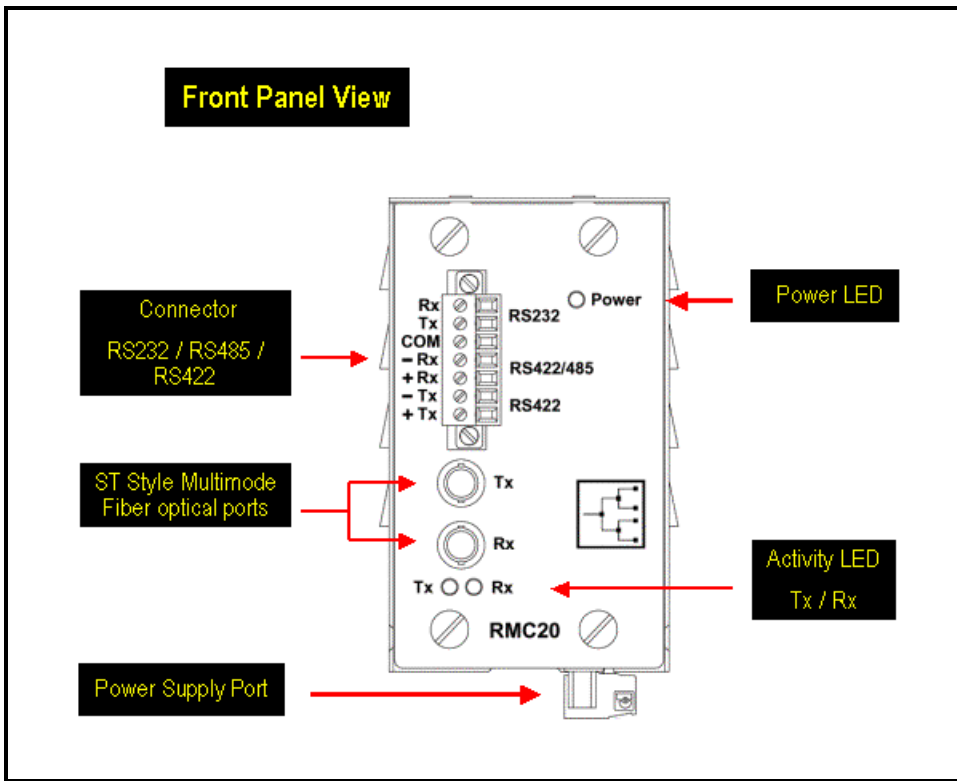

Figure 1: RMC20 Front Panel Detail

The RMC20 LED definitions are as follows:

<i>ITEM</i>	<i>Activity</i>	<i>Comments</i>
Tx LED	Blinking (Yellow)	Transmitting Serial Data
RX LED	Blinking (Yellow)	Receiving Serial Data
Power LED	Solid (Green)	Power On

1.2 RMC20 Side and Bottom View

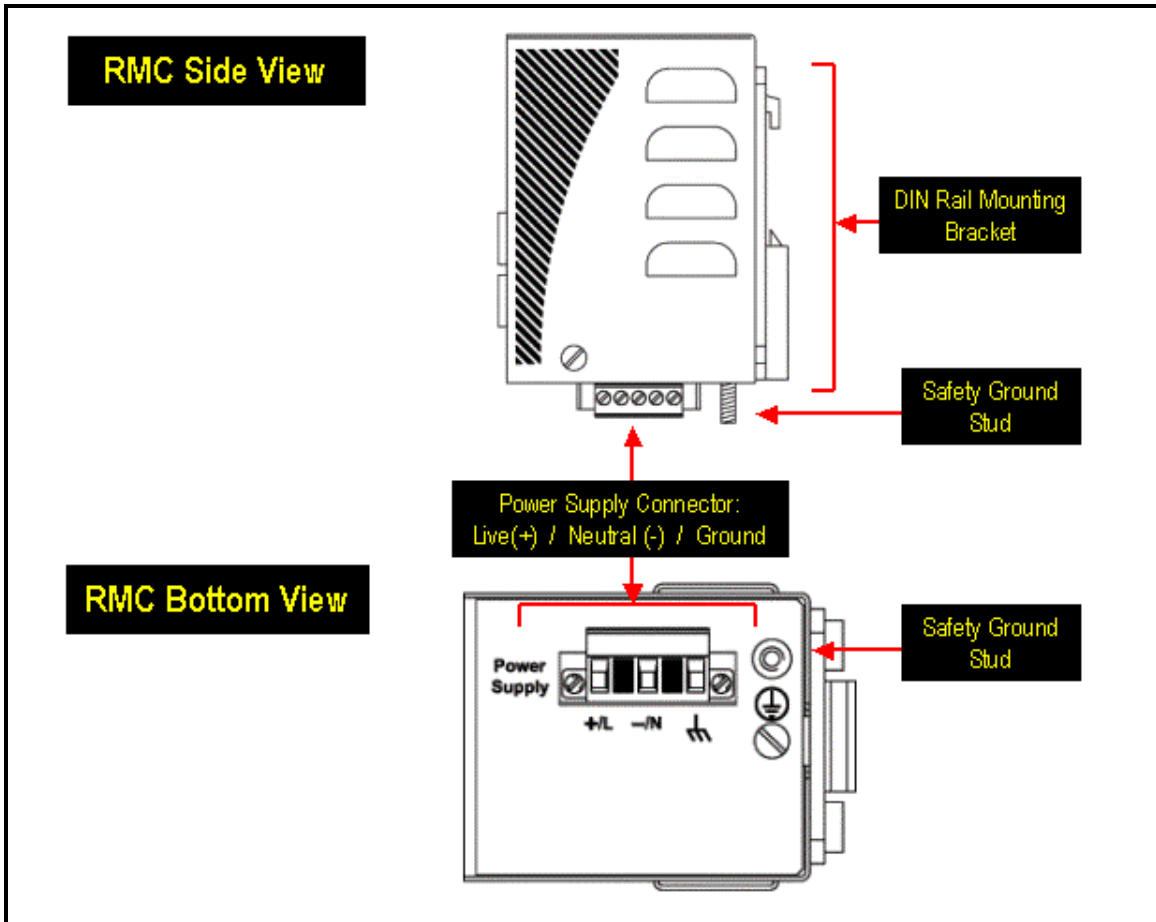

Figure 2: RMC20 Side and Bottom View

2 Installation

2.1 DIN Rail Mounting

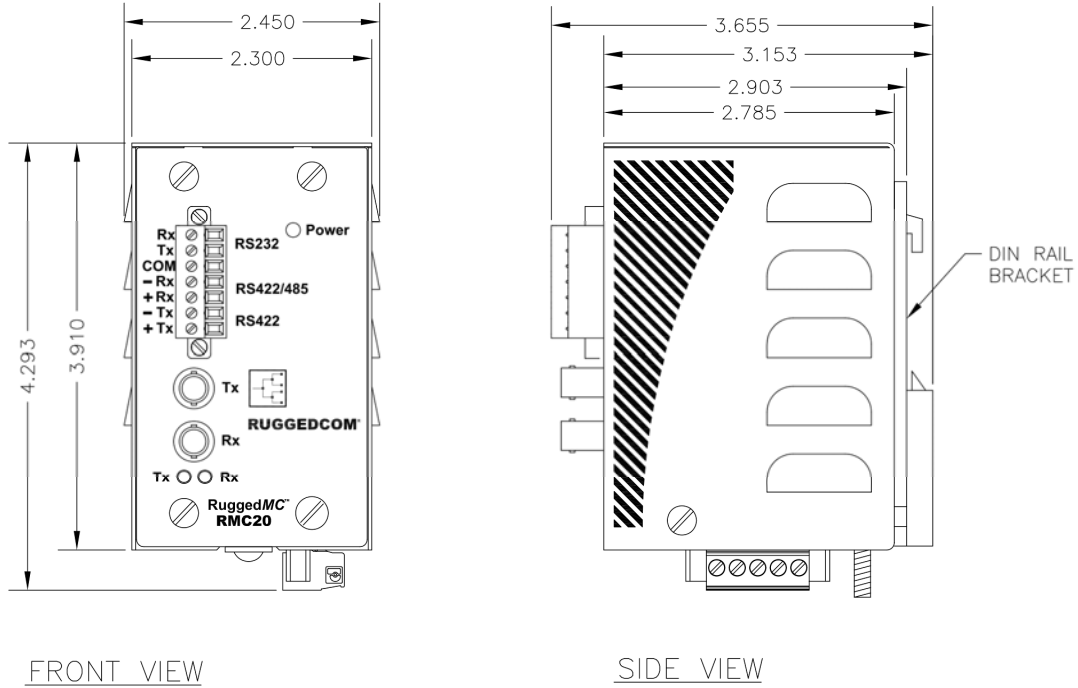

Figure 3: RuggedMC™ DIN Rail Mounting

2.2 Panel Mounting

With the use of an optional panel-mount adapter, the RuggedMC™ series of media converters can be panel mounted. The drawing shown in Figure 4 shows an example of an RMC unit panel mounted using the optional panel mount adapter.

The panel mount adapter can be secured to a panel with three screws. The RuggedMC™ product is easily mounted onto the panel mount adapter via the two metal clips on either side of the unit, and a single screw located on the bottom.

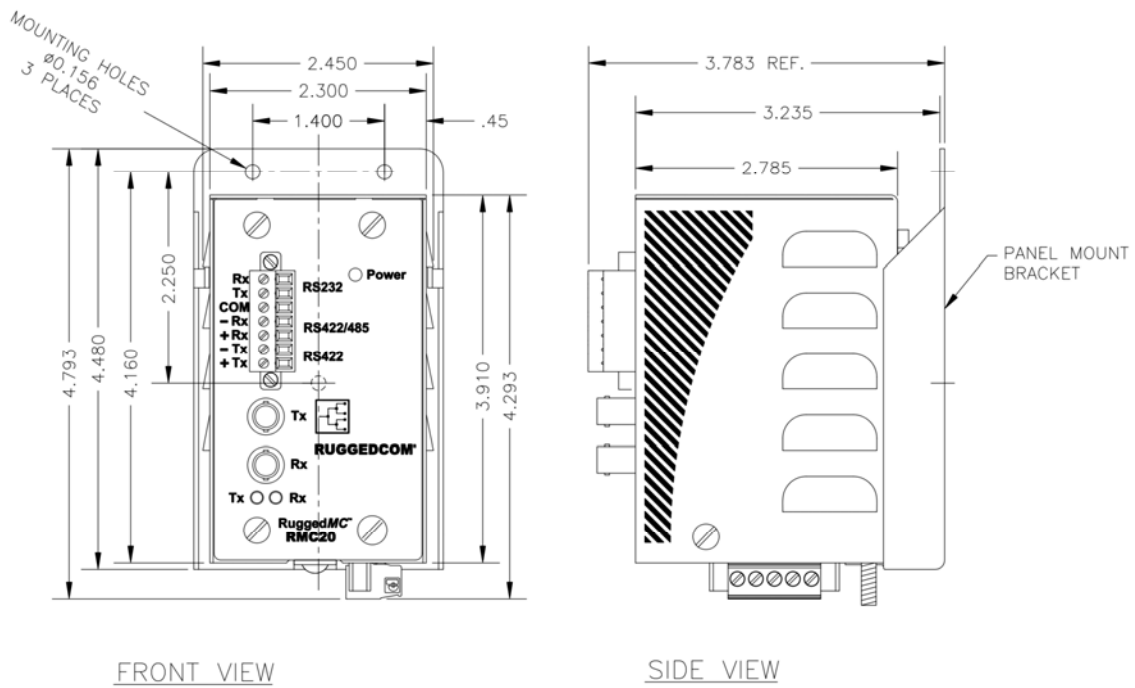

Figure 4: RuggedMC™ panel mounted using optional panel mount mounting adapter.

2.3 Power Supply Wiring and Grounding

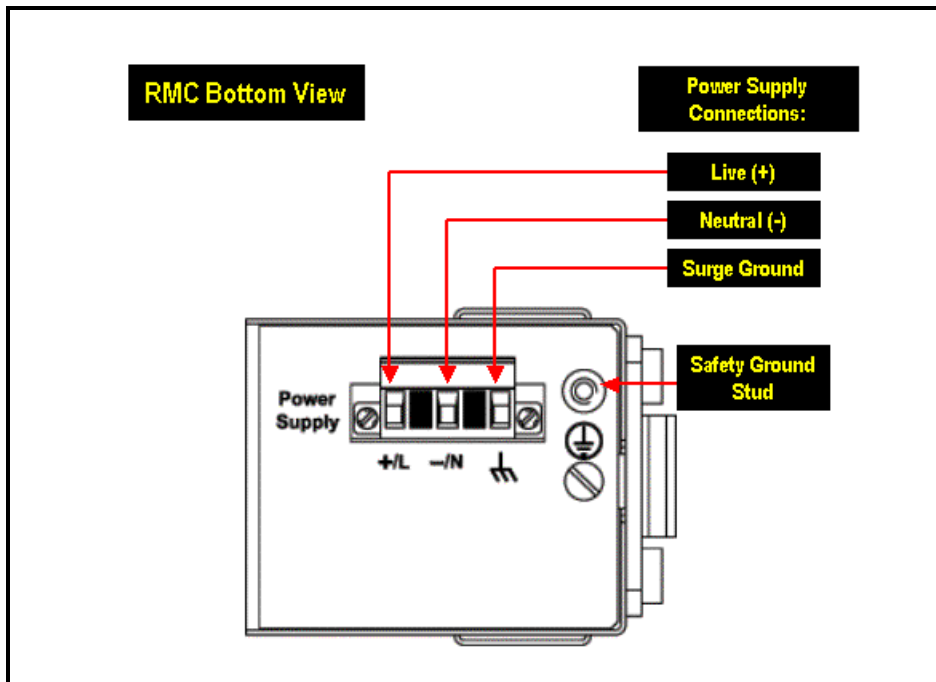

Figure 5: RuggedMC™ Power Supply Inputs

The RuggedMC™ power supply inputs are identical and are connected as follows:

1. **+/L** = DC (+) / AC (Hot) is connected to the positive (+) terminal if the power source is DC or to the (Hot) terminal if the power source is AC.
2. **-/N** = DC (-) / AC (Neutral) is connected to the negative (-) terminal if the power source is DC or to the (Neutral) terminal if the power source is AC.
3. **Surge Ground** is connected to the Safety Ground via a braided cable or other appropriate grounding wire. Surge Ground is used as the ground conductor for all surge and transient suppression circuitry internal to the RuggedMC™.
4. **Safety Ground** should be connected to the power supply ground. This should be the *safety ground* for AC inputs or the equipment *ground bus* for DC inputs.

Note: *Surge Ground must be disconnected from Chassis Ground during HIPOT (Dielectric strength) testing.*

Notes:

1. *For 125/250VDC rated equipment: An appropriately rated 300VDC circuit breaker must be installed within 3 meters of unit.*
2. *For 110/230VAC rated equipment: An appropriately rated 250VAC circuit breaker must be installed within 3 meters of the unit*
3. *A circuit breaker is not required for 48 or 24VDC rated equipment.*
4. *For multiple supplies, separate circuit breakers must be installed. Equipment must be installed according to the applicable country wiring codes.*

2.4 Serial Ports – Signal Description

The RMC20 is equipped with a seven-terminal phoenix style connector. This connector can accommodate one RS232 connection, and one RS485/422 connection. Figure 6 shows the connections for RS232, RS485, and RS422 communications. The following sections describe installation details for respective ports.

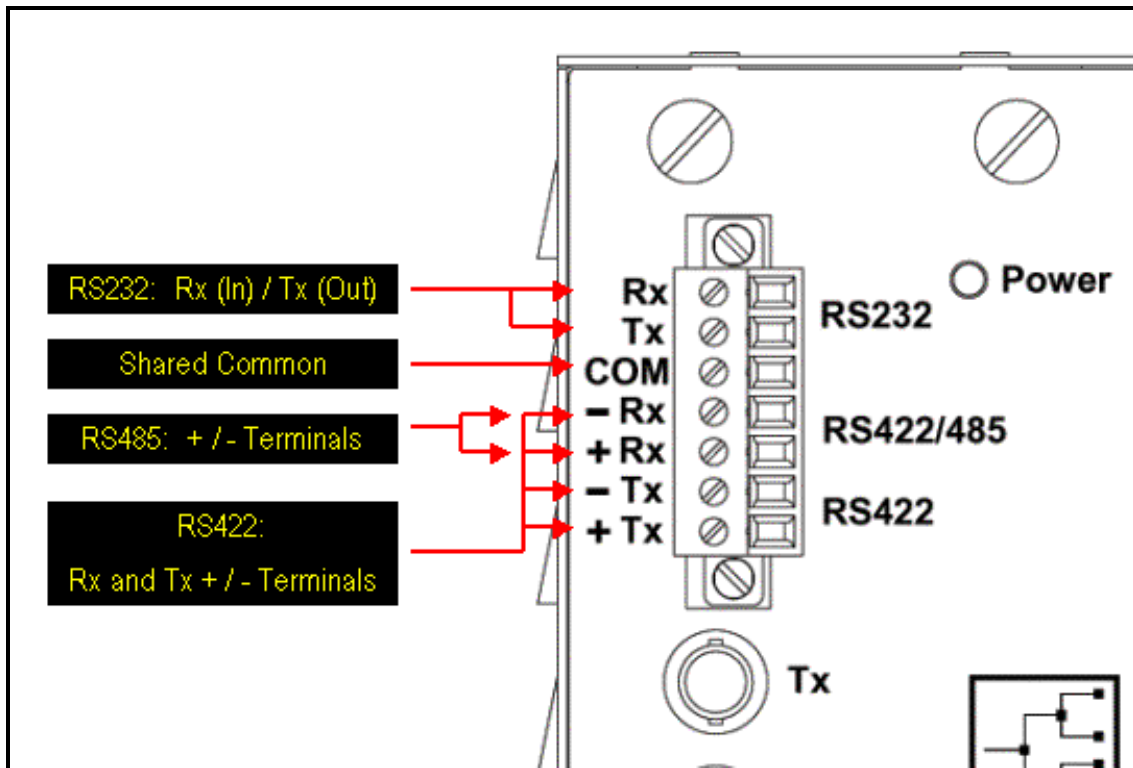

Figure 6: Serial RS232, RS485, and RS422 terminal block connections

2.4.1 RS232 Data Ports

The RMC20 is equipped with a single EIA/TIA RS232 compliant port, consisting of three terminals: **Transmit**, **Receive**, and **Common**. The RS232 port is intended for point-to-point applications only. The EIA/TIA guidelines for RS232 communications include (but are not limited to) the following:

1. To minimize the effects of ambient electrical noise, shielded cabling is recommended.
2. Reliable communications within 15m. Greater distances are possible.
3. Communications of up to 120kbaud signal rate.

2.4.2 RS422 and RS485 Data Ports

The RMC20 is equipped with a single RS485 / RS422 data port. In half duplex mode (See section 2.5 for RMC20 DIP switch settings) the RS485 connections (Rx +, Rx -, COM) should be connected. In full-duplex mode the RS422 connections (Rx+, Rx -, Tx+, Tx-, COM) should be connected. Both RS485 and RS422 can accommodate multi-drop networks, for master-slave serial network communications. For both RS485 / RS422 connections, the following general guidelines should be followed:

1. To minimize the effects of ambient electrical noise, shielded cabling is recommended
2. The correct polarity must be observed throughout the daisy chain
3. The number of devices wired should not exceed 32, and total distance should be less than 4000 feet (at 100Kbps)
4. The COM terminal should be connected to the common wire inside the shield.
5. The shield/COM should be grounded at ONE single point to avoid loop currents
6. The twisted pair should be terminated at each end of the chain. (Typically with a 120Ohm resistor and a 10nF capacitor in series across the twisted pair)*

* Both data terminal pairs (Rx +/- and Tx +/-) are terminated by default from the factory. To remove termination: Open the cover and remove jumper JP1 and/or JP2 (JP1 for Rx+, Rx- terminals, JP2 for Tx+, Tx- terminals) depending on which port termination is NOT required. Termination provided is a 120 Ohm resistor in series with a 10nF capacitor as per the ModBus 1.0 specification. In general termination should be left in place unless it is detrimental to communications.

Note: Transient protection is provided on all RMC20 terminals. Lightning strikes and ground surge currents can cause large momentary voltage differences between ends of communication links. To ensure maximum reliability of the entire link, all equipment should have similar transient protection installed.

Figure 7 details an example RS485 wiring diagram.

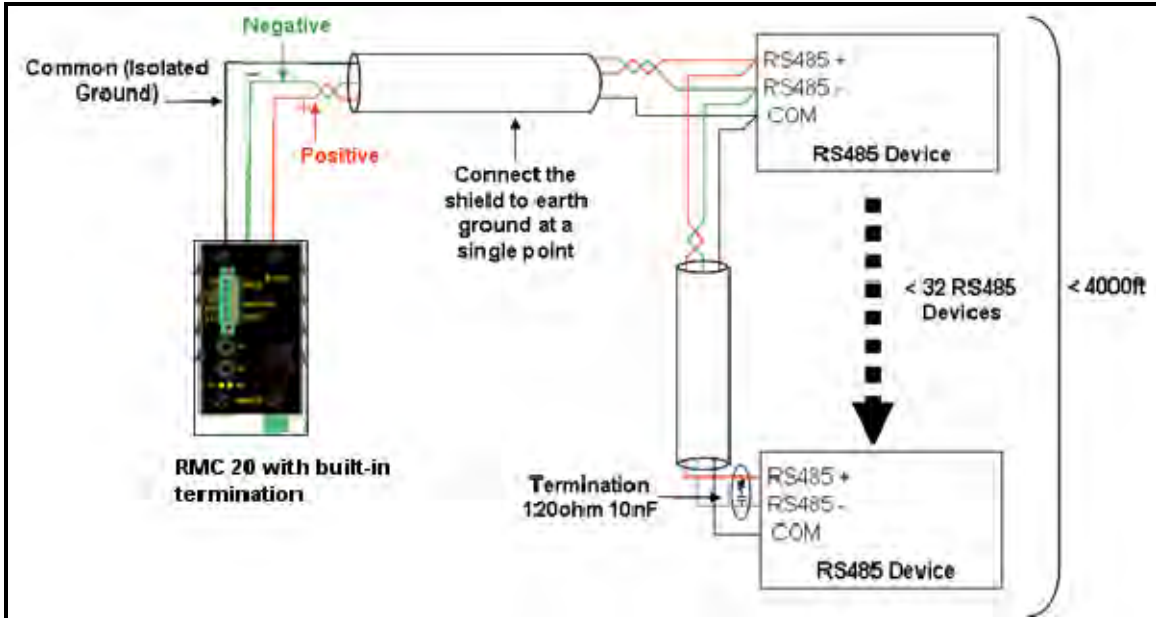

Figure 7: Conceptual RS485 wiring diagram

2.5 RMC20 Configuration

The RMC20 can be configured using the DIP switches located at the bottom of the enclosure. The DIP switches are shown in Figure 8. Using the switches one can change the operating mode of the RMC20.

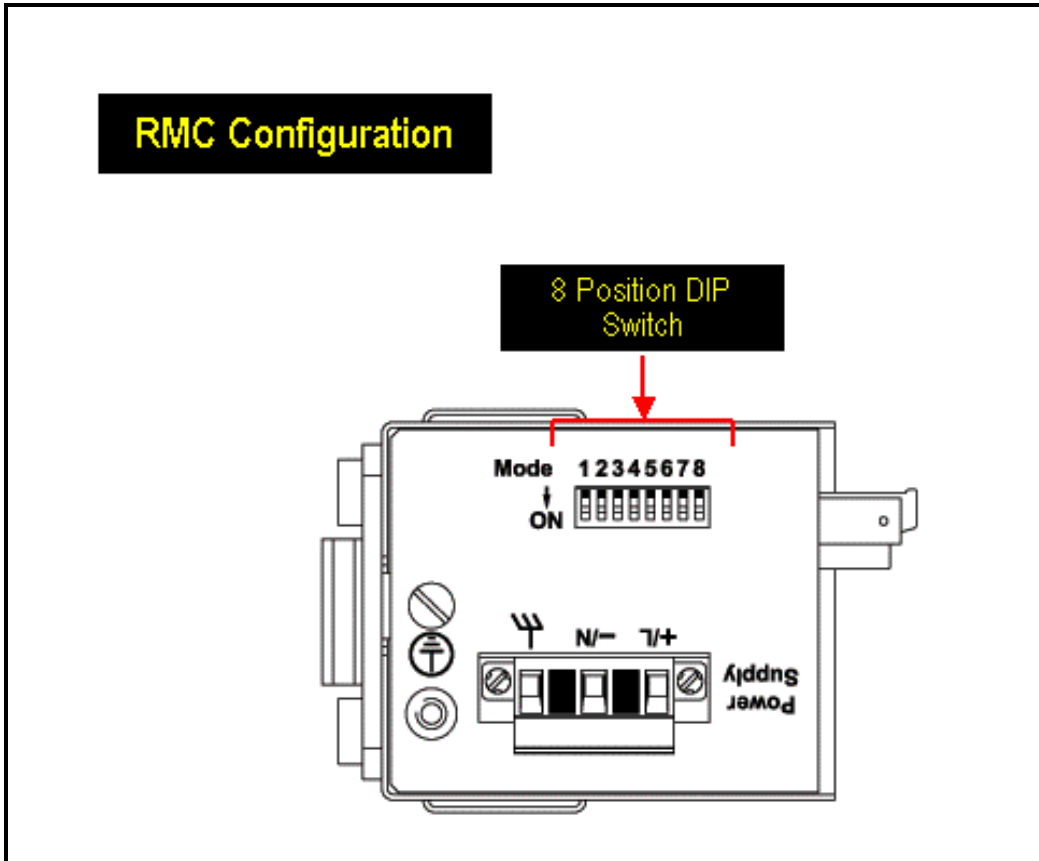

Figure 8: RMC20 8-Position DIP switch location for configuration

RMC20 DIP Switch Configuration Settings Defined		
Position	ON	OFF
1	RS232 to fiber mode	RS485/422 to fiber mode
2	RS232 to RS485/422 conversion mode	Serial (RS232/485/422) to fiber mode
3	Full Duplex Serial (RS232 / RS422)	Half Duplex Serial (RS485)
4	Fiber Repeat ON	Fiber Repeat OFF
5	RESERVED	
6	> 57600 baud	300 – 2400 baud
7	19200 – 57600 baud	
8	4800 – 14400 baud	

The RMC20 is equipped to provide conversion from serial (RS232, RS485, or RS422) to fiber optics, or between serial standards (RS232 to RS485 / RS422). Serial to fiber optic conversion connections can be further implemented in point-to-point, as well as optical loop configurations. To better illustrate all working modes, Sections 2.5.1 through 2.5.3 will show example configuration options, and relevant DIP switch settings.

2.5.1 Serial-to-Fiber Conversion: Point-to-Point

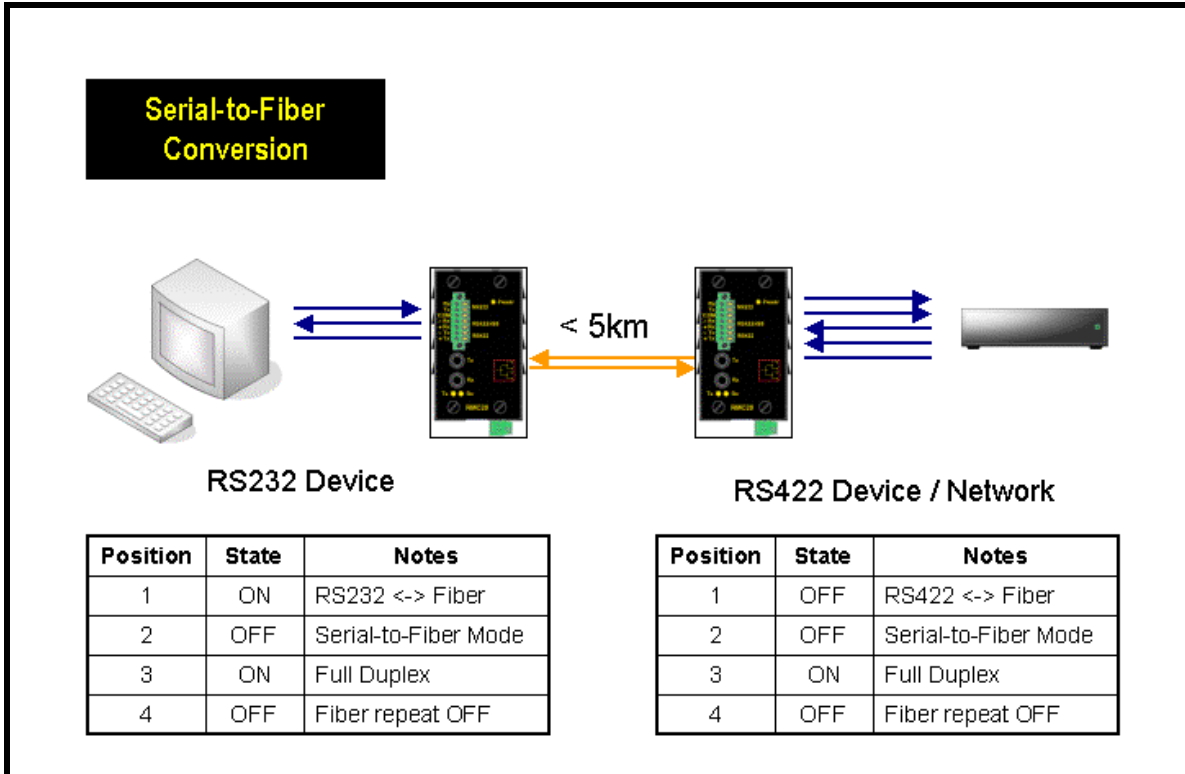

Figure 9: Serial-to-Fiber point-to-point topology

Figure 9 illustrates the serial-to-fiber conversion mode of operation. In this mode serial data is converted directly into light impulses, and transmitted over multimode fiber optics. The serial standard is selected by position 1 of the DIP switches: OFF (default) is for RS485 / RS422, and ON is for RS232. Position 2 should be OFF for serial to fiber conversion. Position 6-8 should be configured if RS485 communications are used, in order to have the appropriate turn-around timer shown below selected. Positions 6-8 do not impact communications in full-duplex mode. (Baud rate lower than 1200bps is not supported in half-duplex or RS485 mode.)

Baud Rate (bps)	DIP6	DIP7	DIP8	Turn-around time
1200-2400	OFF	OFF	OFF	9.5ms
4800-14400	OFF	OFF	ON	2.3ms
19200-57600	OFF	ON	OFF	0.58ms
>57600	ON	OFF	OFF	0.10ms

Turn-around time is the amount of time after the start bit was transmitted and before the transceiver changed back to receiver mode .

2.5.2 Serial Standard Conversion

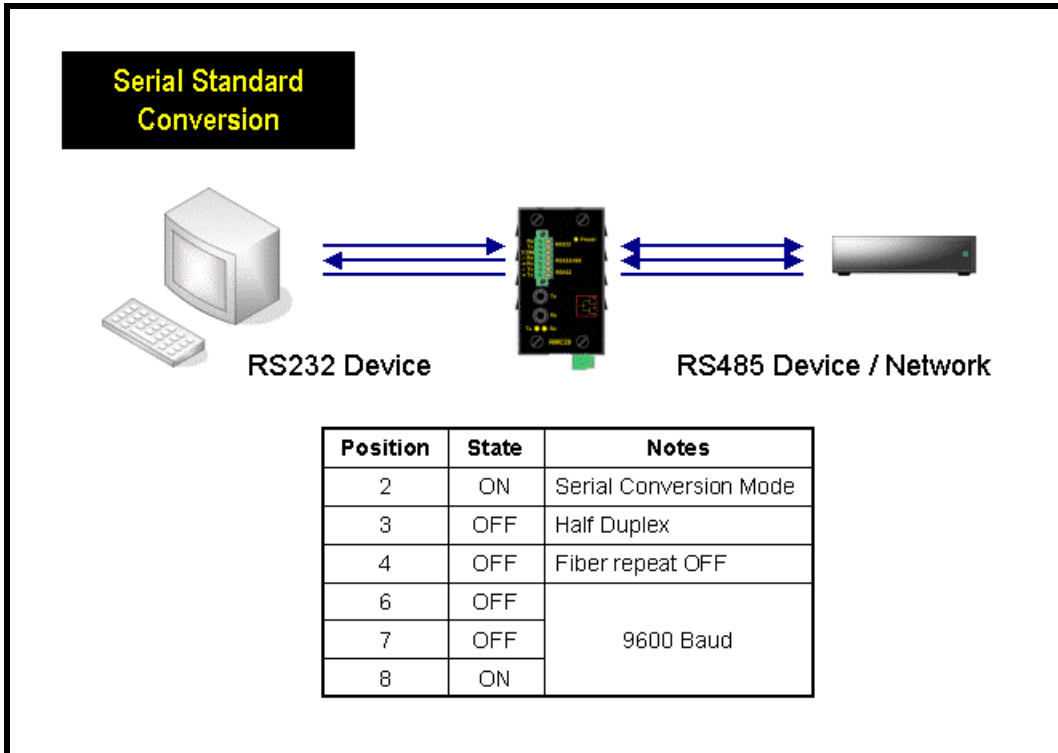

Figure 10: In serial conversion mode, one can convert from RS232 to RS485 / RS422

Figure 10 illustrates the connections for conversion between RS232 and RS485 / 422 devices. In this mode of operation, RS232 voltage levels are converted to the appropriate RS485 or RS422 signaling levels depending on the DIP switch configuration. In this mode of operation position 2 of the DIP switches must be in the ON position. Figure 10 illustrates a RS232 device, connected to an RS485 device or network. Since RS485 requires automatic turn-around, position 3 must be set to the OFF state, and position 6 – 8 of the DIP switches must reflect the proper operating baud rate.

Note: In this mode of operation, no isolation is provided between RS232 device and the RS485/422 network – both devices share the same common terminal. It should be noted that the common terminal on RS232 devices are connected to ground. In some instances (ie when connecting to large RS485 networks), it may be preferential for the user to leave the RS485/RS422 shield terminal unconnected to the RMC20 in this mode.

2.5.3 Serial-to-Fiber Conversion: Loop Topology

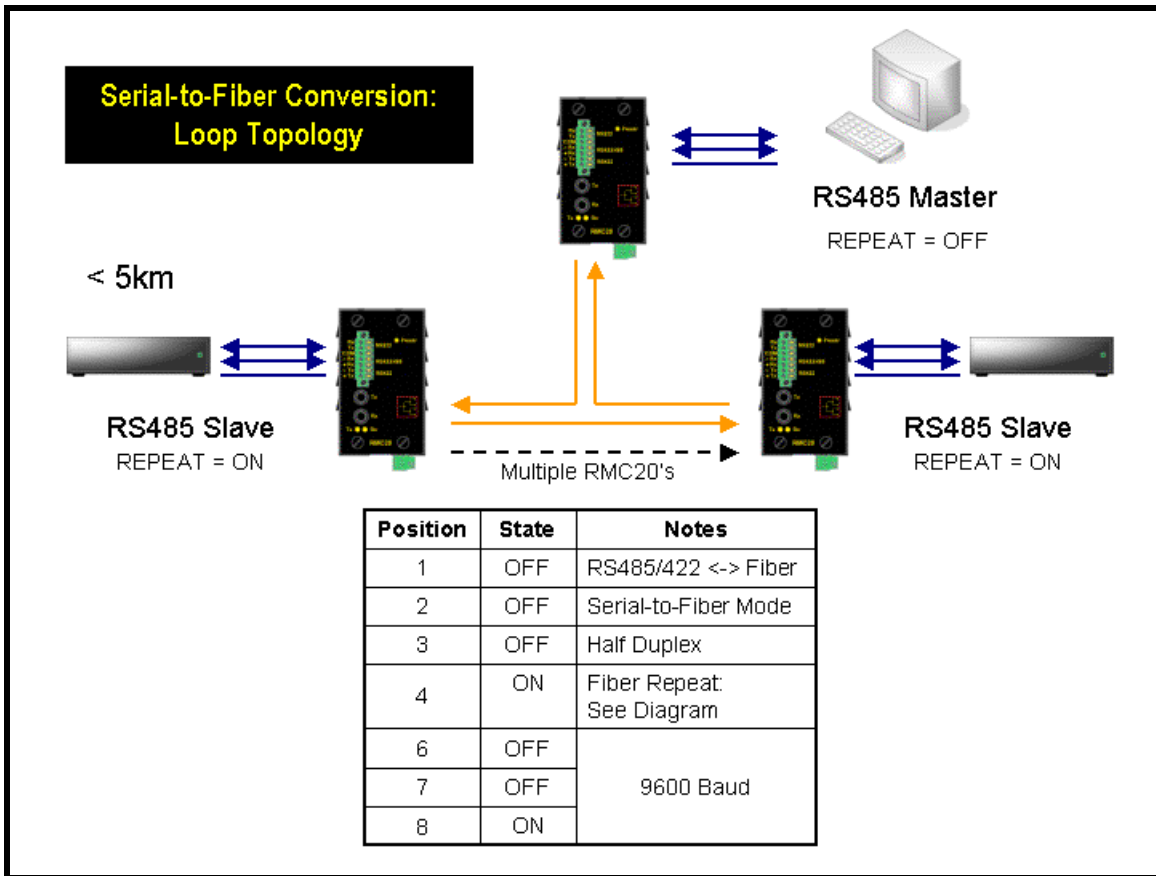

Figure 11: Serial-to-fiber conversion in example optical loop topology

Figure 11 illustrates the optical loop topology that utilizes the RMC20 repeat mode function. The repeat function will optically re-transmit any data received on the optical receiver, in addition to any connected serial devices. As a result, any data transmitted from the master, will be re-transmitted optically to all the slaves. This mode of operation requires that the master device tolerate receiving echoes of transmitted data since any transmissions will be received once again via the optical ring.

This topology can be used for RS232, RS485, or RS422 multi-drop networks. In all cases, all slaves have the repeat function (DIP position 4) ON, while the master is configured with the repeat function OFF. This topology can allow for the mixture of RS232, RS485, and RS422 devices, operating on the same baud rate, on a single optical serial network because the RMC20 utilizes a common optical signaling protocol for all serial standards.

3 Specifications

3.1 Power Supply Specifications

<i>Power Supply Type</i>	<i>Minimum Input</i>	<i>Maximum Input</i>	<i>Internal Fuse Rating</i>	<i>Maximum Power Consumption</i>
24 VDC	18 VDC	36 VDC	3.15A(T) ²	3 W
48 VDC	36 VDC	72 VDC	3.15A(T) ²	
HI (88/300 VDC) ¹ HI (120/240 VAC) ¹	88 VDC 85 VAC	300 VDC 264 VAC	3.15A(T) ²	

Notes: 1 – This is the same power supply for both AC and DC.

2 – (T) Denotes time-delay fuse

3.2 Fiber Optical Port Specifications

<i>Parameter</i>	<i>Specifications</i>
<i>Mode</i>	Multimode
<i>Connector</i>	ST
<i>Typical Dist. (km)</i>	5
<i>Optical Wavelength (nm)</i>	820
<i>Cable Size</i>	50/125
<i>Core/Cladding (um)</i>	62.5/125
<i>Tx Power (dBm)</i>	-13
<i>Rx Sensitivity (dBm)</i>	-33.5
<i>Rx Saturation (dBm)</i>	-11
<i>Typical Budget (dB)</i>	17.5

Notes:

1. Maximum segment length is greatly dependent on factors such as fiber quality, and number of patches and splices. Please consult RuggedCom sales associates when determining maximum segment distances.
2. All optical power numbers are listed as dBm averages.

3.3 Mechanical Specifications

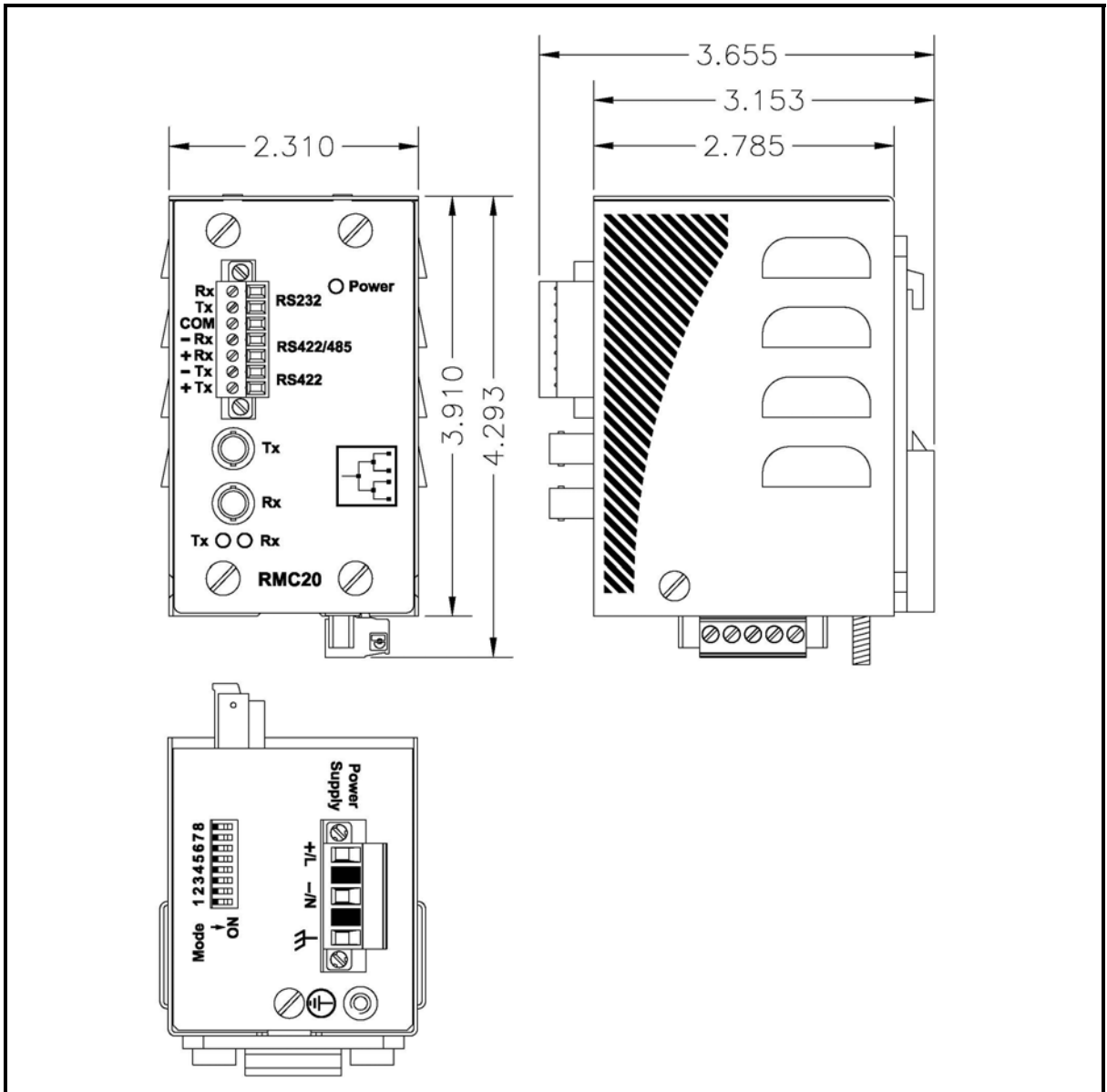

Figure 12: Mechanical Dimensions

<i>Parameter</i>	<i>Value</i>	<i>Comments</i>
Dimensions	4.30 x 2.40 x 3.30 inches (110) x (61) x (84) mm	(Length x Width x Height)
Weight	1.5 lb (0,68 Kg)	
Enclosure	18 gauge Galvanized Steel	

3.4 Operating Environment

<i>Parameter</i>	<i>Range</i>	<i>Comments</i>
Ambient Operating Temperature	-40 to 85°C	Ambient Temperature as measured from a 30cm radius surrounding the center of the RuggedMC™ enclosure.
Ambient Relative Humidity	5% to 95%	Non-condensing
Ambient Storage Temperature	-40 to 85°C	

4 Type Tests

4.1 IEC 61850-3 Type Tests

Test	Description		Test Levels	Severity Levels
IEC 61000-4-2	ESD	Enclosure Contact	+/- 8kV	4
		Enclosure Air	+/- 15kV	4
IEC 61000-4-3	Radiated RFI	Enclosure ports	20 V/m	x
IEC 61000-4-4	Burst (Fast Transient)	Signal ports	+/- 4kV @ 2.5kHz	x
		D.C. Power ports	+/- 4kV	4
		A.C. Power ports	+/- 4kV	4
		Earth ground ports	+/- 4kV	4
IEC 61000-4-5	Surge	Signal ports	+/- 4kV line-to-earth, +/- 2kV line-to-line	4
		D.C. Power ports	+/- 2kV line-to-earth, +/- 1kV line-to-line	3
		A.C. Power ports	+/- 4kV line-to-earth, +/- 2kV line-to-line	4
IEC 61000-4-6	Induced (Conducted) RFI	Signal ports	10V	3
		D.C Power ports	10V	3
		A.C. Power ports	10V	3
		Earth ground ports	10V	3
IEC 61000-4-8	Magnetic Field	Enclosure ports	40 A/m continuous, 1000 A/m for 1 s	N/A
IEC 61000-4-29	Voltage Dips & Interrupts	D.C. Power ports	30% for 0.1s, 60% for 0.1s, 100% for 0.05s	N/A
IEC 61000-4-11		A.C. Power ports	30% for 1 period, 60% for 50 periods 100% for 5 periods, 100% for 50 periods ²	N/A
IEC 61000-4-12	Damped Oscillatory	Signal ports	2.5kV common, 1kV differential mode @ 1MHz	3
		D.C. Power ports	2.5kV common, 1kV differential mode @ 1MHz	3
		A.C. Power ports	2.5kV common, 1kV differential mode @ 1MHz	3
IEC 61000-4-16	Mains Frequency Voltage	Signal ports	30V Continuous, 300V for 1s	4
		D.C. Power ports	30V Continuous, 300V for 1s	4
IEC 61000-4-17	Ripple on D.C. Power Supply	D.C. Power ports	10%	3
IEC 60255-5	Dielectric Strength	Signal ports	2kV AC (Fail-Safe Relay output)	N/A
		D.C. Power ports	1.5kVDC	N/A
		A.C. Power ports	2kVAC	N/A
IEC 60255-5	H.V. Impulse	Signal ports	5kV (Fail-Safe Relay output)	N/A
		D.C. Power ports	5kV	N/A
		A.C. Power ports	5kV	N/A

Table 1 - IEC 61850-3 Type Tests

4.2 IEEE 1613 Type Tests

IEEE Test	IEEE 1613 Clause	Description		Test Levels
C37.90.3	9	ESD	Enclosure Contact	+/- 8kV
			Enclosure Air	+/- 15kV
C37.90.2	8	Radiated RFI	Enclosure ports	35 V/m
C37.90.1	7	Fast Transient	Signal ports	+/- 4kV @ 2.5kHz
			D.C. Power ports	+/- 4kV
			A.C. Power ports	+/- 4kV
			Earth ground ports	+/- 4kV
C37.90.1	7	Oscillatory	Signal ports	2.5kV common mode @ 1MHz
			D.C. Power ports	2.5kV common & differential mode @ 1MHz
			A.C. Power ports	2.5kV common & differential mode @ 1MHz
C37.90	6	H.V. Impulse	Signal ports	5 kV (Failsafe Relay)
			D.C. Power ports	5 kV
			A.C. Power ports	5 kV
C37.90	6	Dielectric Strength	Signal ports	2kVAC
			D.C. Power ports	1.5kVDC
			A.C. Power ports	2kVAC

Table 2 - IEEE 1613 Type Tests

Notes:

- If the unit contains copper ports, the IEEE 1613 conformance is Class 1 (During disturbance, errors may occur but recovery is automatic).
- If the unit contains all fiber ports, the IEEE 1613 conformance is Class 2 (During disturbance, no errors will occur).

4.3 IEC Environmental Type Tests

Test	Description		Test Levels	Severity Levels
IEC 60068-2-1	Cold Temperature	Test Ad	-40 deg. C, 16 Hours	N/A
IEC 60068-2-2	Dry Heat	Test Bd	+85 deg. C, 16 Hours	N/A
IEC 60068-2-30	Humidity (Damp Heat, Cyclic)	Test Db	95% (non-condensing), 55°C, 6 cycles	N/A
IEC 60255-21-1	Vibration		2g @ (10-150) Hz	Class 2
IEC 60255-21-2	Shock		30g @ 11 ms	Class 2

Table 3 - Environmental Type Tests

Note:

- Class 2 refers to “Measuring relays and protection equipment for which a very high security margin is required or where the vibration levels are very high, (e.g. shipboard application and for severe transportation conditions).”

5 Agency Approvals

<i>Agency</i>	<i>Standards</i>	<i>Comments</i>
CSA, CE	CSA C22.2 No. 60950, UL 60950, EN 60950 EN 61000-6-2	Approved
FCC	FCC Part 15, Class A	Approved
CISPR	EN55022, Class A	Approved
FDA/CDRH	21 CFR Chapter 1, Subchapter J	Compliant
IEC/EN	EN60825-1:1994 + A11:1996 + A2:2001	Compliant

6 Warranty

RuggedCom warrants this product for a period of five (5) years from date of purchase. For warranty details, visit <http://www.ruggedcom.com/> or contact your customer service representative.

Should this product require warranty or service contact the factory at:

RuggedCom Inc.
300 Applewood Crescent
Concord, Ontario
Canada L4K 5C7
Phone: +1 905 856 5288
Fax: +1 905 856 1995