

RuggedSwitch[®] RS1600 Family

16-Port Managed Fiber Optical Ethernet Switches



Installation Guide

www.ruggedcom.com

Copyright

COPYRIGHT © 2010 RuggedCom Inc. ALL RIGHTS RESERVED

Dissemination or reproduction of this document, or evaluation and communication of its contents, is not authorized except where expressly permitted. Violations are liable for damages. All rights reserved, particularly for the purposes of patent application or trademark registration.

This document contains proprietary information, which is protected by copyright. All rights are reserved. No part of this document may be photocopied, reproduced or translated to another language without the prior written consent of RuggedCom Inc.

Disclaimer of liability

We have checked the contents of this manual against the hardware and software described. However, deviations from the description cannot be completely ruled out.

RuggedCom shall not be liable for any errors or omissions contained herein or for consequential damages in connection with the furnishing, performance, or use of this material.

The information given in this document is reviewed regularly and any necessary corrections will be included in subsequent editions. We appreciate any suggested improvements. We reserve the right to make technical improvements without notice.

Registered Trademarks

RuggedRated™, ROS™ and eRSTP™ are trademarks of RuggedCom Inc. RuggedRouter® and RuggedSwitch® are registered trademarks of RuggedCom Inc. Other designations in this manual might be trademarks whose use by third parties for their own purposes would infringe the rights of the owner.

Contacting RuggedCom

Corporate Headquarters	US Headquarters	Europe Headquarters
RuggedCom Inc. 300 Applewood Crescent Concord, Ontario Canada, L4K 5C7	RuggedCom 1930 Harrison St., Suite 209 Hollywood, Florida USA, 33020	RuggedCom Unit 41, Aztec Centre, Aztec West, Almondsbury, Bristol United Kingdom BS32 4TD
Tel: +1 905 856 5288 Fax: +1 905 856 1995 Toll-free: 1 888 264 0006	Tel: +1 954 922 7938 ext. 103 Fax: +1 954 922 7984 Toll-free: 1 888 264 0006	Tel: +44 1454 203 404 Fax: +44 1454 203 403
Email: RuggedSales@RuggedCom.com		

Technical Support

Toll Free (North America): 1 866 922 7975
International: +1 905 856 5288
Email: Support@RuggedCom.com

Web: www.RuggedCom.com

Federal Communications Commission Radio Frequency Interference Statement

This equipment has been tested and found to comply with the limits for a Class A digital device pursuant to Part 15 of the FCC Rules. These limits are designed to provide reasonable protection against harmful interference when the equipment is operated in a commercial environment. This equipment generates, uses and can radiate radio frequency energy and, if not installed and used in accordance with the instruction manual, may cause harmful interference to radio communications. Operation of this equipment in a residential area is likely to cause harmful interference in which case the user will be required to correct the interference at his expense.

Caution

This product contains a laser system and is classified as a "CLASS 1 LASER PRODUCT".

Use of controls or adjustments or performance of procedures other than those specified herein may result in hazardous radiation exposure. This product contains no user-serviceable parts. Attempted service by unauthorized personnel shall render all warranties null and void.

Should this device require service see the "Warranty" section of this installation guide.

Important

This unit should be installed in a restricted access location where access can only be gained by service personnel or users who have been instructed about the reasons for the restrictions applied to the location and about any precautions that shall be taken; and access is through the use of a tool or lock and key, or other means of security, and is controlled by the authority responsible for the location.

Table of Contents

1	Product Overview	5
1.1	Functional Overview.....	5
1.2	Feature Highlights.....	5
1.3	RS1600 Front Panel Description	6
1.4	RS1600T Front Panel Description.....	8
1.5	RS1600F Front Panel Description	9
1.6	RS1600 Family Rear Panel Description	10
2	Installation	11
2.1	Rack Mounting.....	11
2.2	Power Supply Wiring and Grounding.....	12
2.2.1	Single Power Supply – AC Input.....	13
2.2.2	Dual Power Supplies – AC Inputs	13
2.2.3	Single Power Supply – DC Input.....	14
2.2.4	Dual Power Supplies – DC Inputs	14
2.2.5	Dual Power Supplies – DC and AC Inputs.....	15
2.3	HIPOT (Dielectric Strength) Testing.....	16
2.4	Failsafe Output Wiring and Specifications.....	17
2.5	RS232 Port Wiring.....	18
2.6	RJ45 Twisted-Pair Data Ports	19
3	Technical Specifications	20
3.1	Operating Environment.....	20
3.2	Power Supply Specifications	20
3.3	Failsafe Relay Specifications.....	20
3.4	Data Port Specifications.....	20
3.5	Fiber Optical Specifications.....	21
3.6	Mechanical Specifications	22
4	Type Tests.....	23
4.1	IEC 61850-3 Type Tests	23
4.2	IEEE 1613 Type Tests	24
4.3	IEC Environmental Type Tests.....	24
5	Agency Approvals	25
6	Warranty.....	25

1 Product Overview

1.1 Functional Overview

The RuggedSwitch™ RS1600 series are substation hardened fiber optical Ethernet switches specifically designed to operate in harsh environments such as those found in electric utility substations and harsh industrial environments.

Specifically tested to the same standards as mission critical protective relaying equipment, (i.e. IEEE 1613 and IEC 60255) the RS1600 family is ideally suited to form the Ethernet network in a UCA2 (Utility Communications Architecture 2.0) based substation automation network. Because they were designed to meet the demands of the substation environment it is also ideally suited for industrial automation networks based on Industrial Ethernet. The reliability of the RS1600 family exceeds that of commercial Ethernet switches by having no rotating mechanical parts such as cooling fans and by utilizing high-temperature solid-state components. The RS1600 series also offers dual redundant power supplies each of which can be specified to operate from different voltage sources which allows for increased network availability and maximum network design flexibility.

1.2 Feature Highlights

- Utility Grade (i.e. substation hardened) per IEEE 1613, IEC 60255, IEC 61850-3, IEC 61000-6-5 standards
- Operating temperature: -40° to 85°C (no fan)
- Radiated RF Immunity: 35V/m per ANSI/IEEE C37.90.2
- Dual, redundant power supply options: 12, 24 or 48 VDC, or HI (88-300VDC or 85-264VAC)
- Failsafe output relay for critical failure or error alarming
- RS1600:
 - 12 – 10BaseFL fiber optical ports
 - 2 – 100BaseFX fiber optical uplink ports
 - 2 – 10/100BaseTx RJ45 ports (optional)
- RS1600T:
 - 14 – 10/100BaseTx RJ45 ports
 - 2 – 100BaseFX fiber optical uplink ports
- RS1600F:
 - 16 – 100BaseFX fiber optical ports
- Advanced layer 2 switching functions: 802.1p Message Prioritization, 802.1Q VLAN
- Full-duplex operation (no collisions)

1.3 RS1600 Front Panel Description

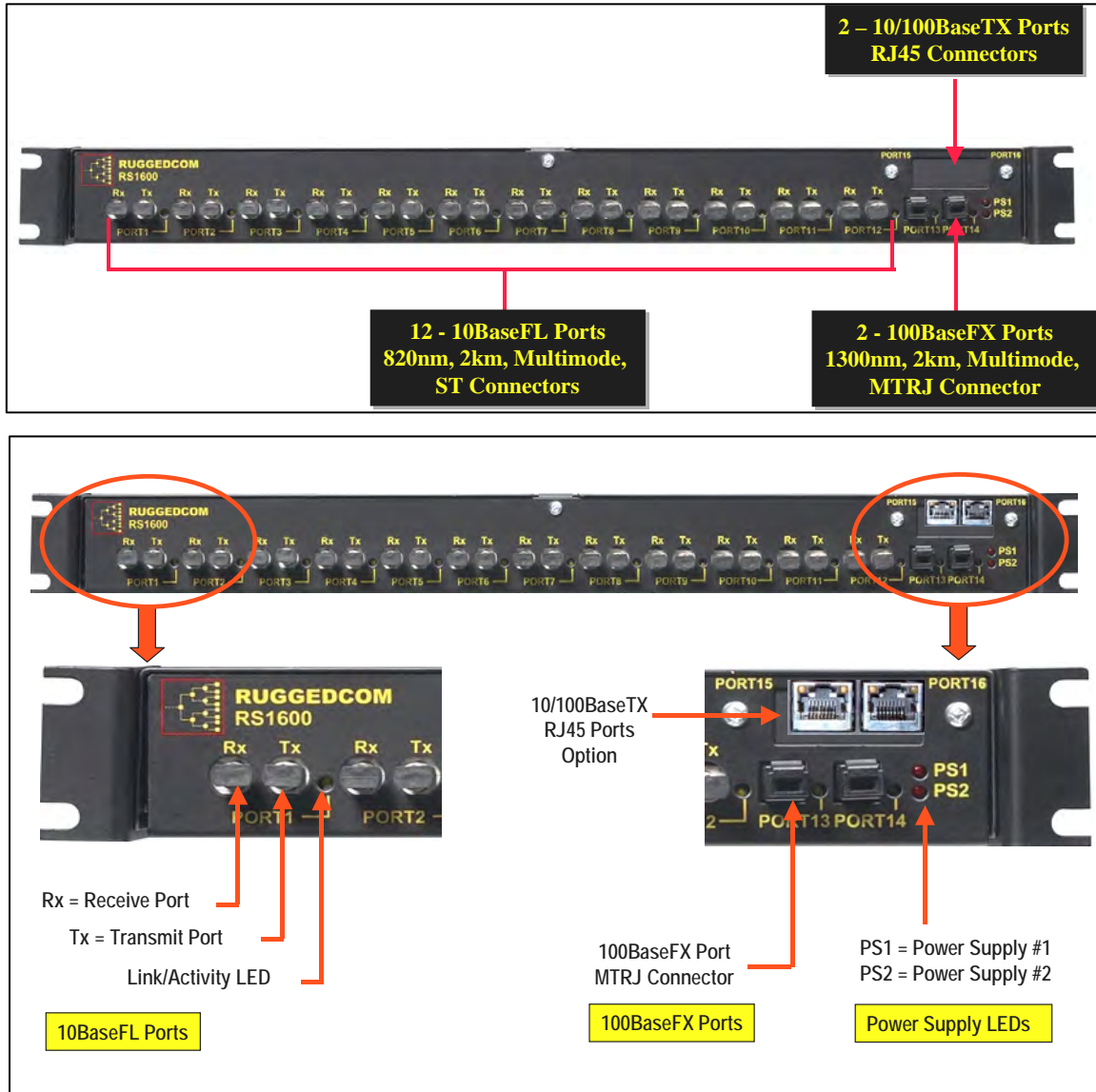

Figure 1: RS1600 Front Panel Detail

ITEM	Activity	Comments
Port(1-14) Link/Activity LED	Solid	Link Established
	Blinking – Once per second	Tx, Rx Activity
Optional RJ45 Ports (15-16) Link/Activity LEDs	Active Right LED	Link Established
	Active Left LED	100BaseT Link
	Inactive Left LED	10BaseT Link
PS1 LED	Solid	Power Supply 1 ON
PS2 LED	Solid	Power Supply 2 ON

NOTE: If your RS1600 was ordered without the RJ45 Uplink Ports, then there will be no reset function available although a reset label is shown on the faceplate. This does not apply to the RS1600F and RS1600T.

1.4 RS1600T Front Panel Description

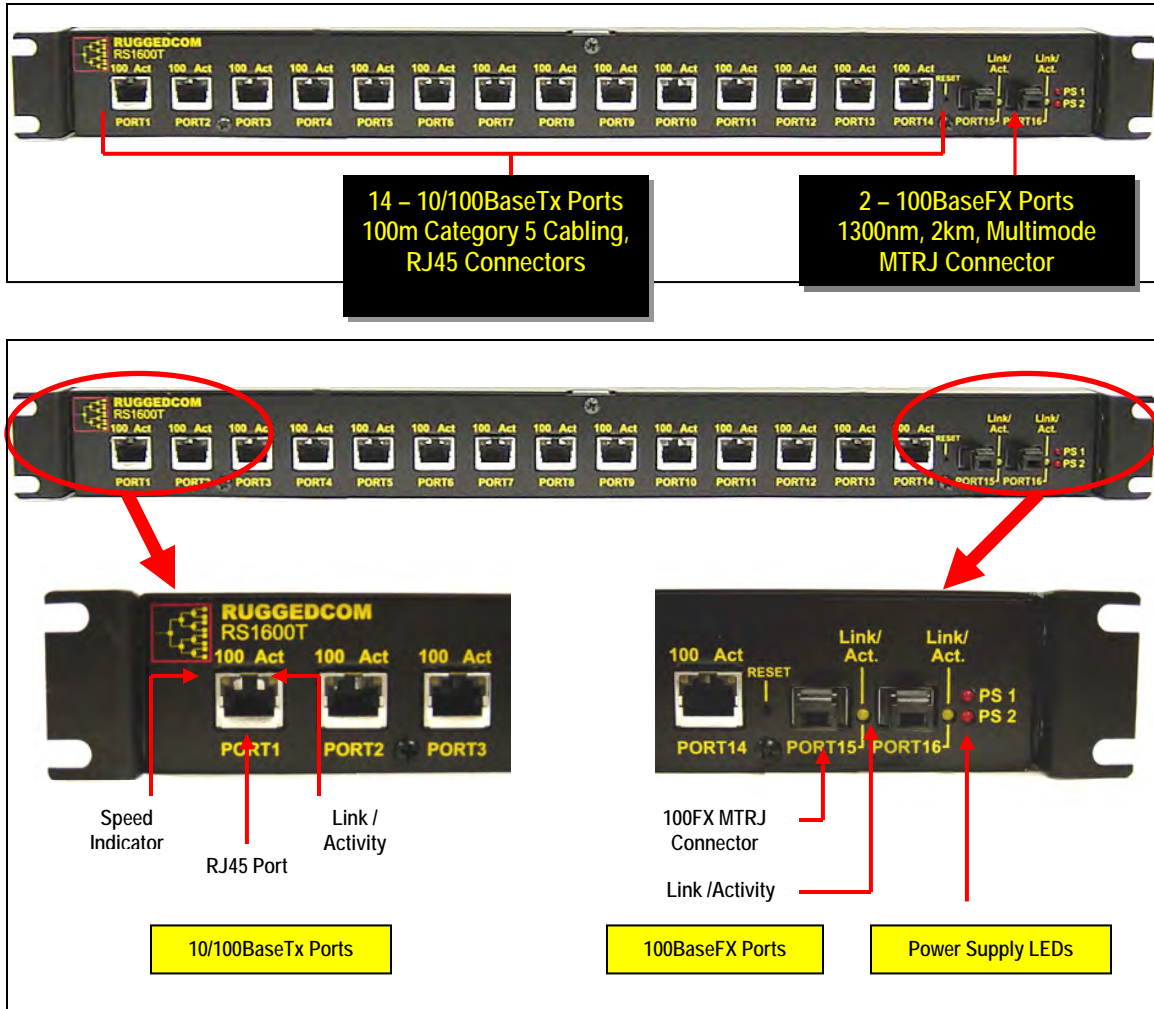

Figure 2: RS1600T Front Panel Detail

ITEM	Activity	Comments
Ports 1 - 14 Link/Activity LEDs	100 LED On	100BaseTx Link
	100 LED Off	10BaseT Link
	Act LED On	Link Established
	Act LED Blinking	Activity
	Act LED Off	No Link Established
Ports 15 – 16 Link/Activity LEDs	LED On	Link Established
	LED Blinking	Activity
	Led Off	No Link Established
PS1 – PS2 LED	On	Power Supply ON
	Off	Power Supply OFF

1.5 RS1600F Front Panel Description

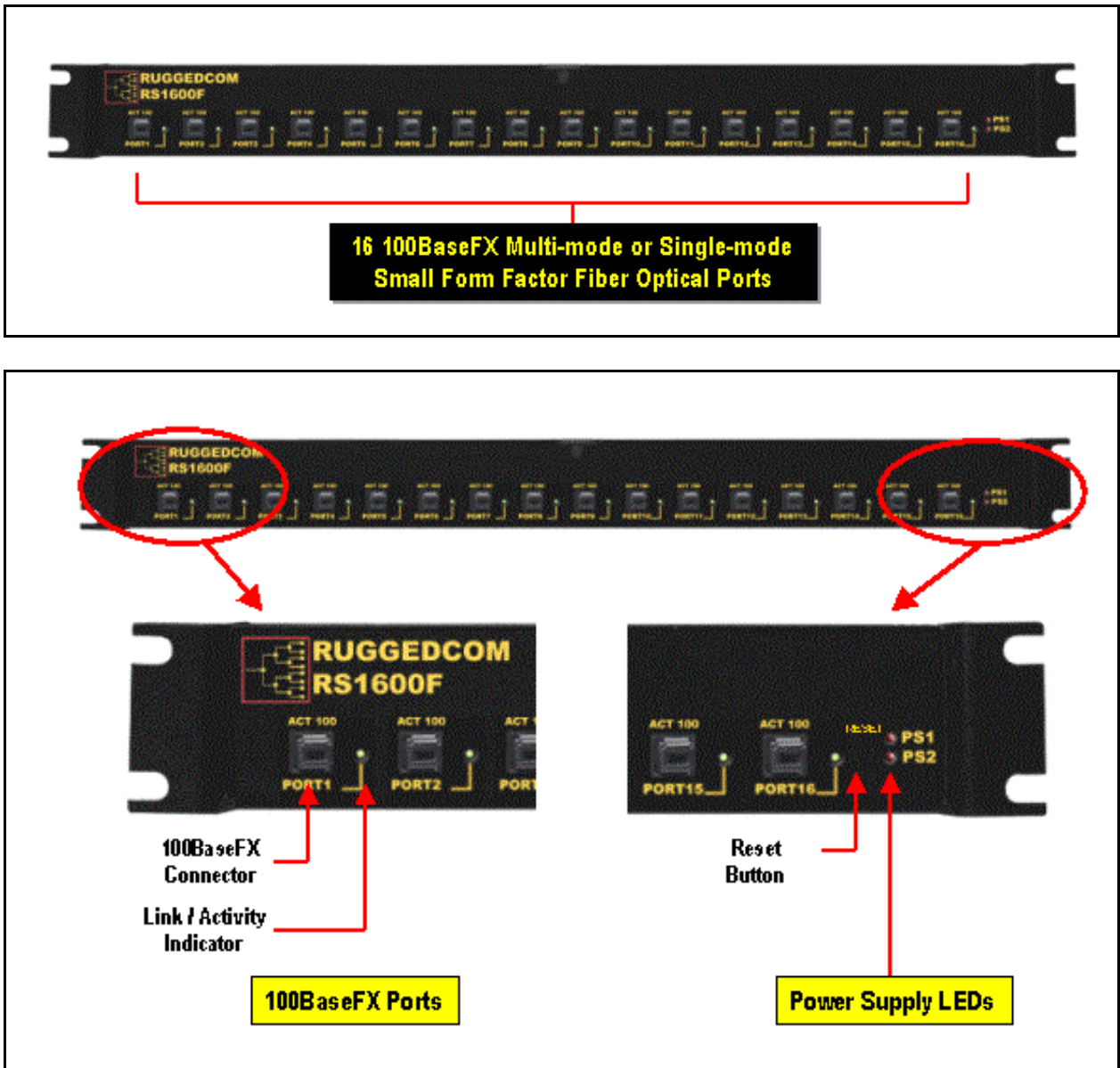

Figure 3: RS1600F Front Panel Detail

ITEM	ACTIVITY	COMMENTS
Ports 1 – 16 Link/Activity LEDs	On	Link Established
	Blinking	Activity
	Off	No Link Established
PS1 – PS2 LED	On	Power Supply ON
	Off	Power Supply OFF

1.6 RS1600 Family Rear Panel Description

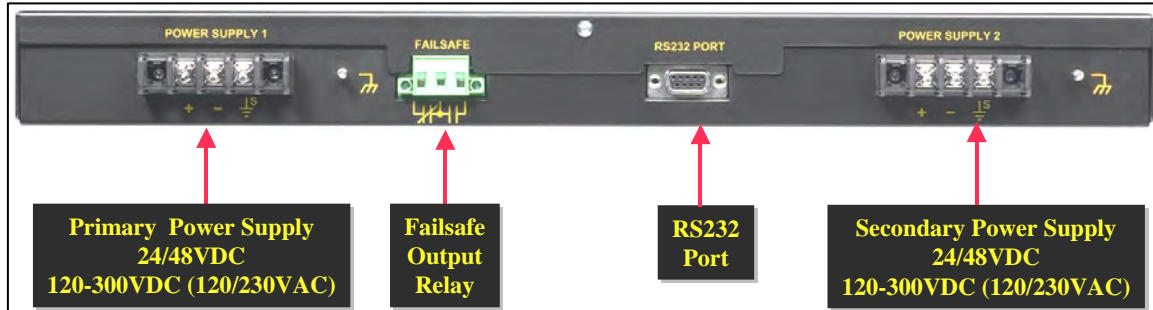

Figure 4: RS1600 Family Rear Panel Description

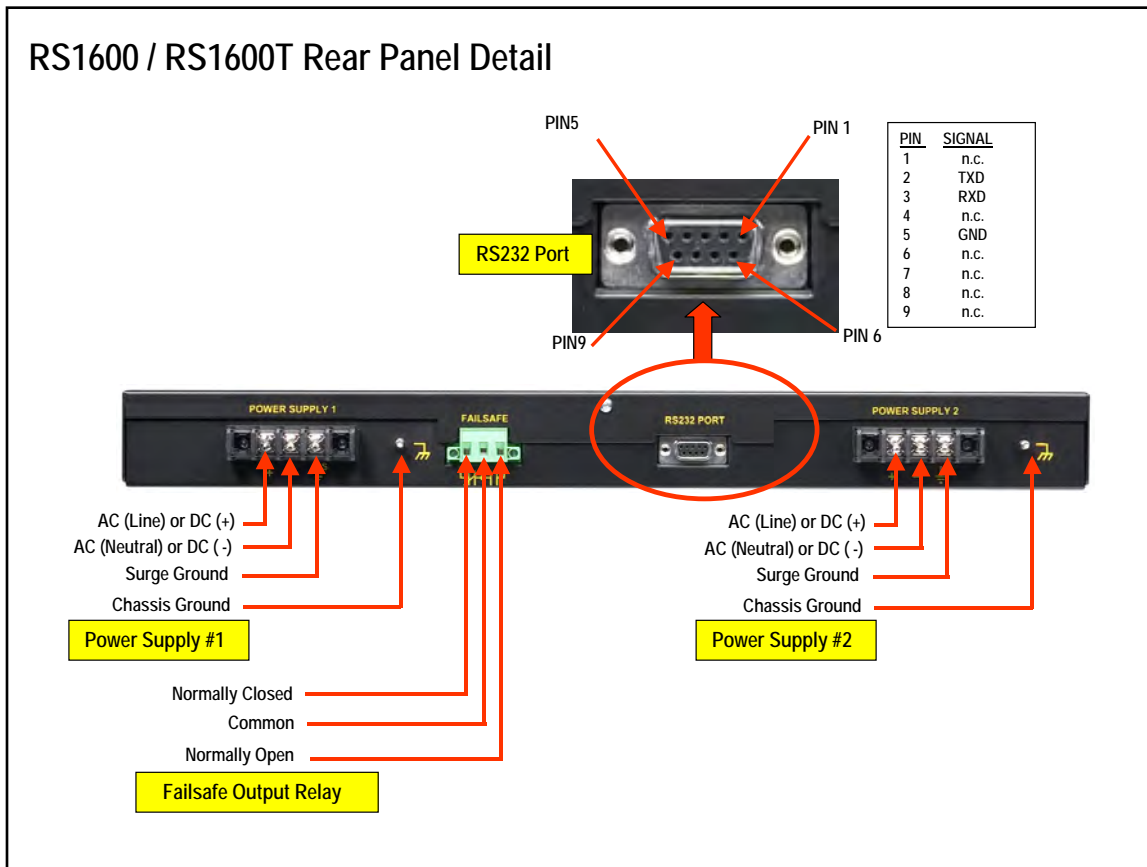

Figure 5: RS1600 Family Rear Panel Detail

2 Installation

2.1 Rack Mounting

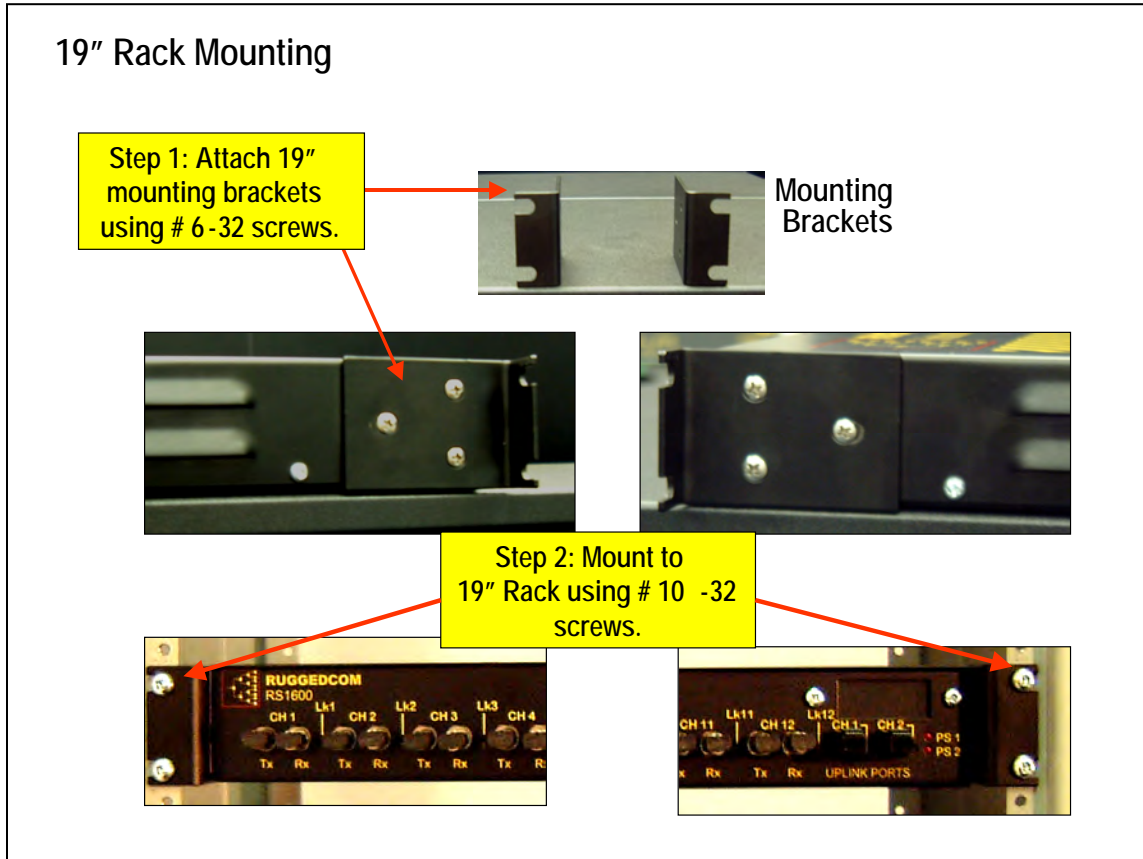

Figure 6: RS1600 Family 19" Rack Mounting

NOTE: Since heat within RS1600 products is channeled to the enclosure, it is recommended that 1 rack unit of space (1.75") be kept unpopulated and free of equipment above each RS1600 series product to allow for a small amount of convective airflow. Although forced airflow is not necessary, any increase in airflow will result in a reduction of ambient temperature that will improve long-term reliability of all equipment mounted within the rack space.

2.2 Power Supply Wiring and Grounding

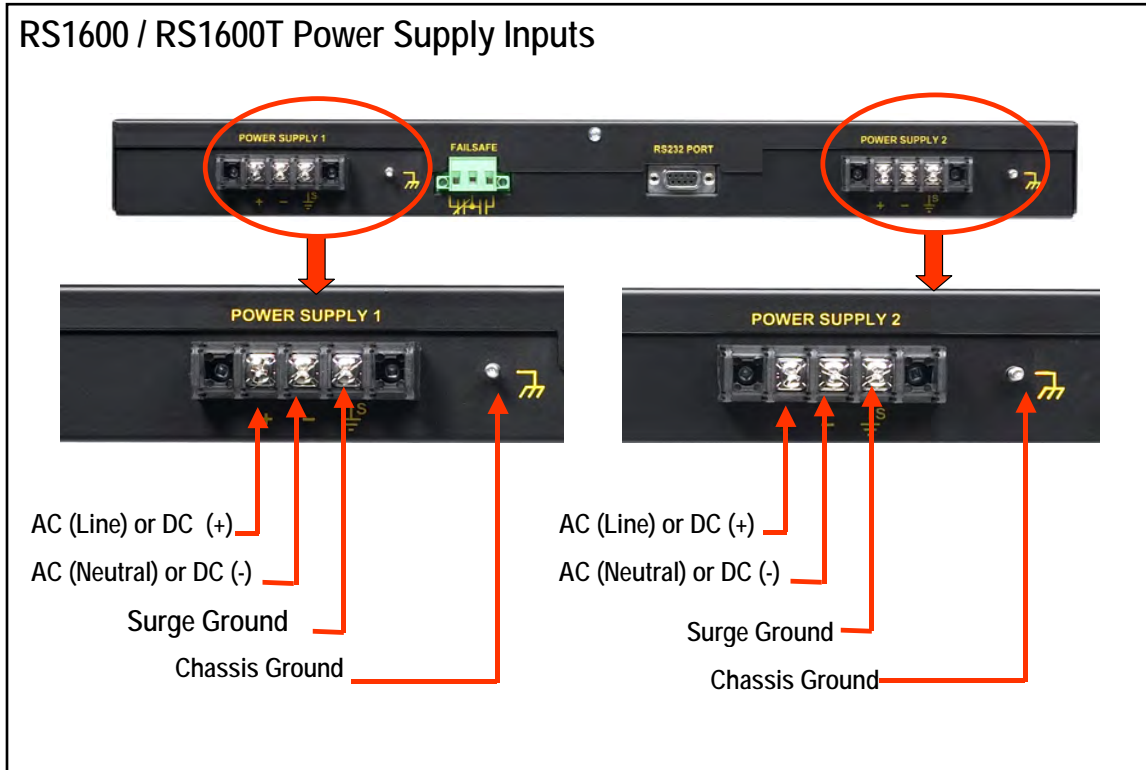

Figure 7: RS1600 Family Power Supply Inputs

The RS1600 family supports dual redundant power supplies – “Power Supply 1” and “Power Supply 2” (see Figure 7). Each power supply has a set of identical inputs that perform the following:

1. **+/H** is connected to the positive (+) terminal if the power source is DC or to the (Hot) terminal if the power source is AC.
2. **-/N** is connected to the negative (-) terminal if the power source is DC or to the (Neutral) terminal if the power source is AC.
3. **Surge Ground** is connected to the Chassis Ground via a braided cable or other appropriate grounding wire. Surge Ground is used as the ground conductor for all surge and transient suppression circuitry internal to the RS1600. **NOTE:** Surge Ground must be disconnected from Chassis Ground during HIPOT (dielectric strength) testing.
4. **Chassis Ground** is connected to the Safety Ground terminal for AC inputs or the equipment *ground bus* for DC inputs.

Sections 2.2.1 to 2.2.5 describe connections for single, dual and mixed AC and DC power supply inputs.

2.2.1 Single Power Supply – AC Input

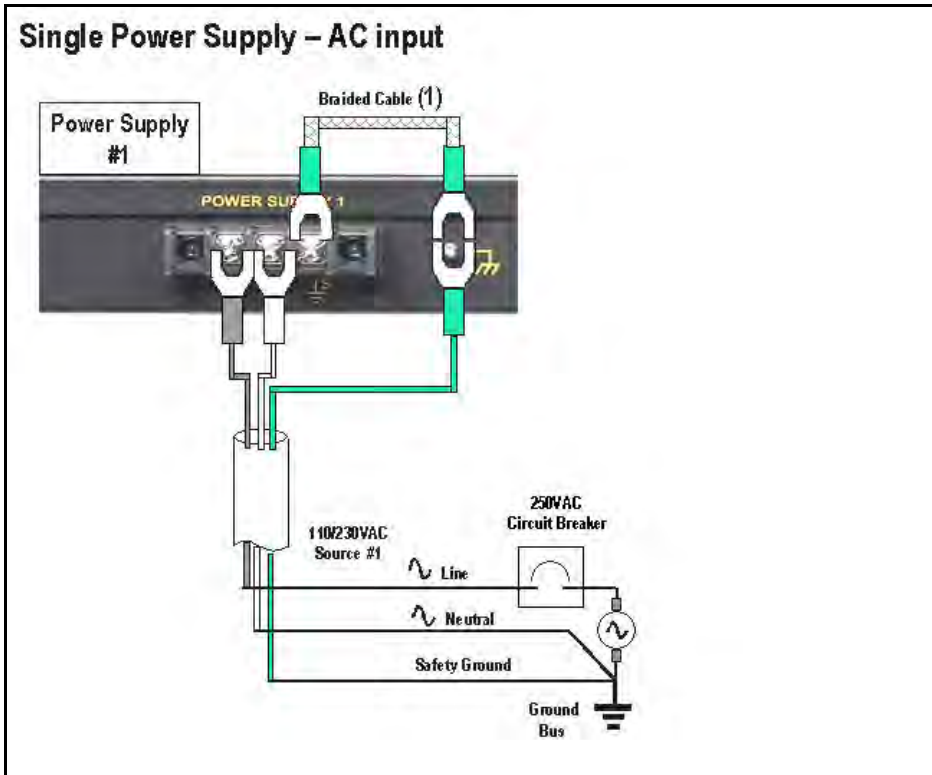

Figure 8: Single Power Supply – AC Input

2.2.2 Dual Power Supplies – AC Inputs

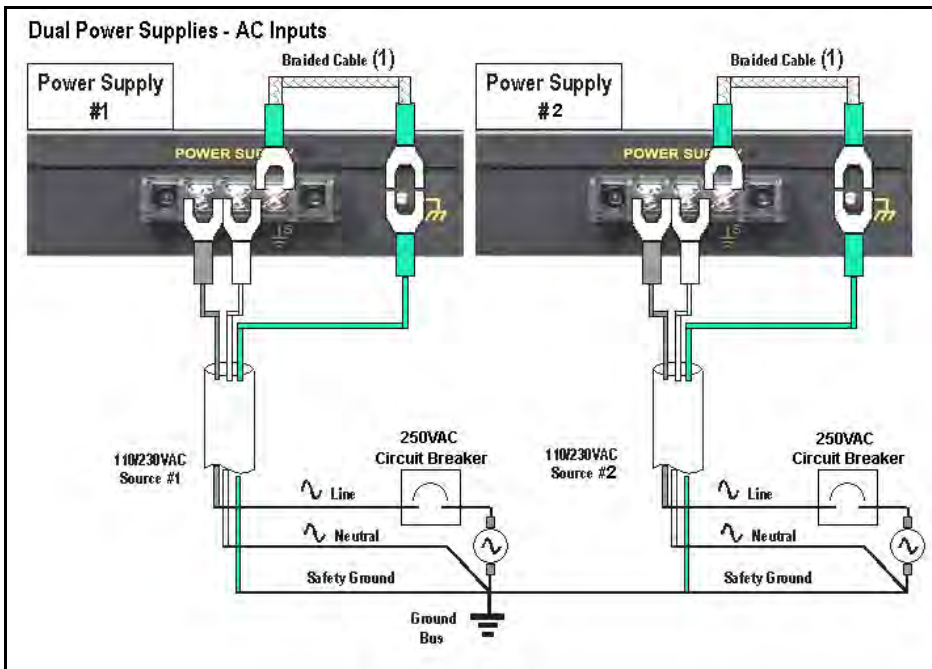

Figure 9: Dual Power Supplies – AC Inputs

2.2.3 Single Power Supply – DC Input

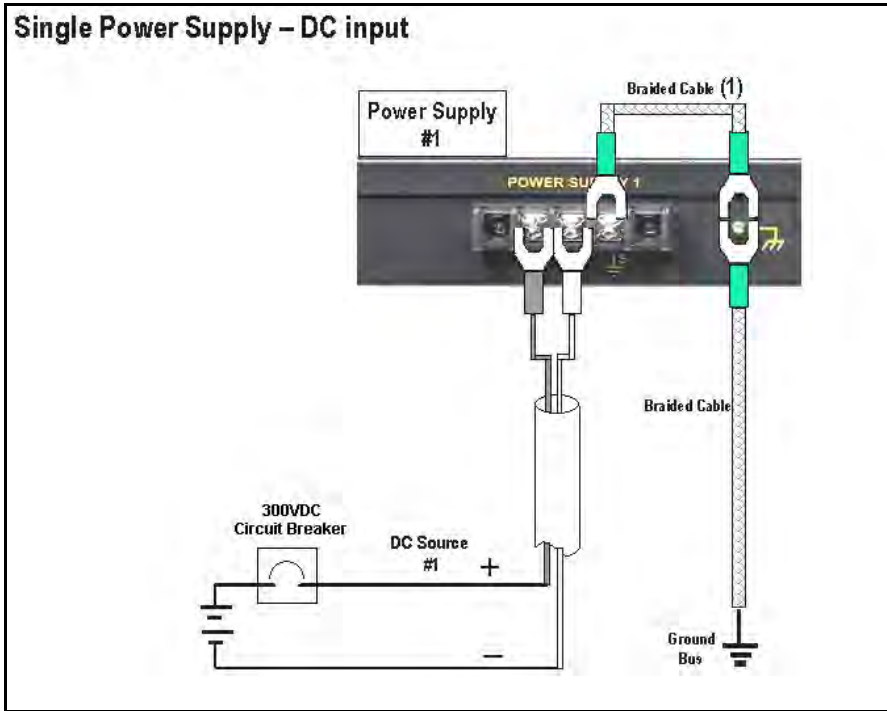

Figure 10: Single Power Supply – DC Input

2.2.4 Dual Power Supplies – DC Inputs

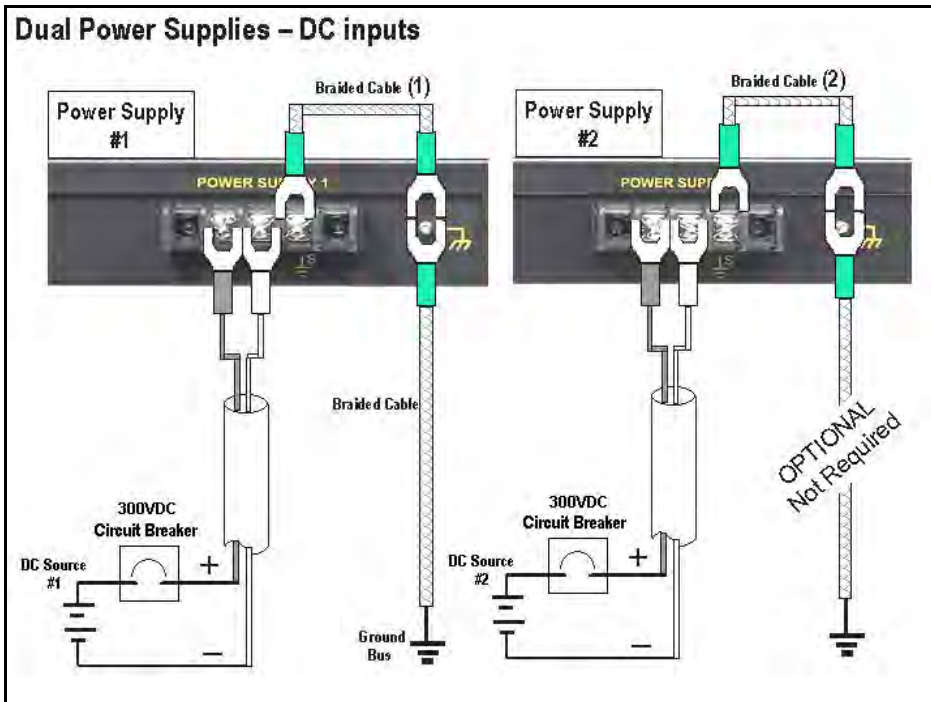

Figure 11: Dual Power Supplies – DC Inputs

2.2.5 Dual Power Supplies – DC and AC Inputs

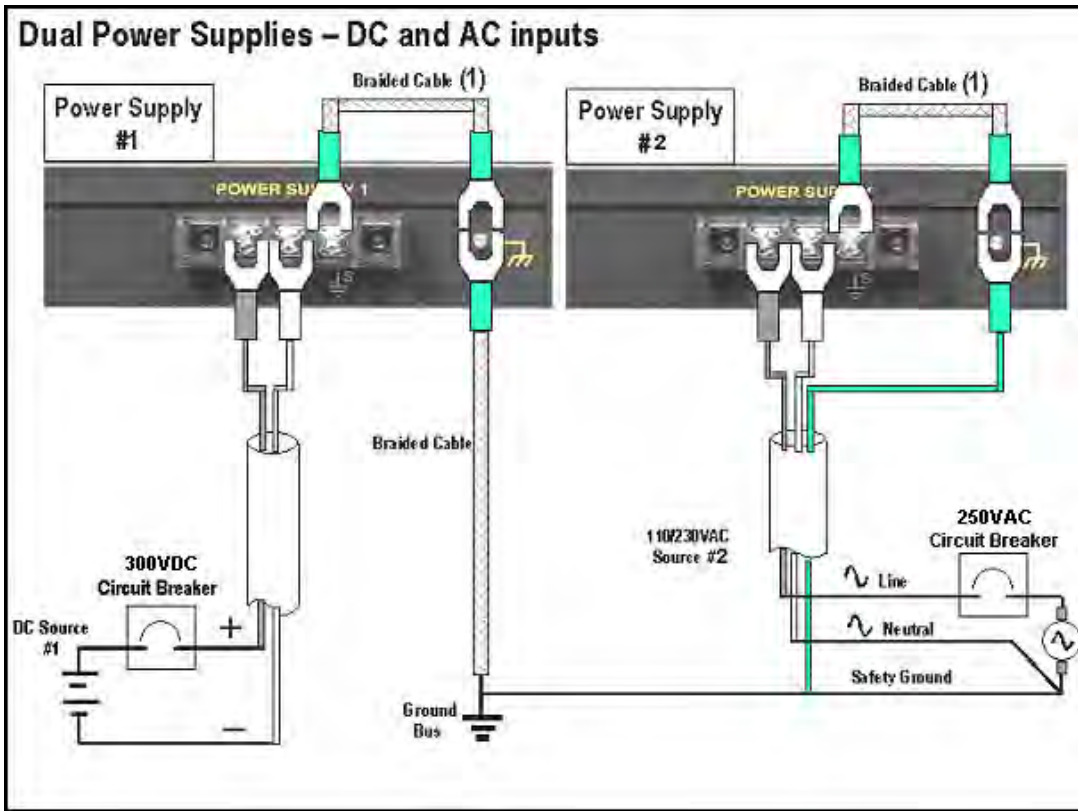

Figure 12: Dual Power Supplies – DC and AC Inputs

NOTES:

1. 88-300VDC rated equipment: A 300VDC appropriately rated circuit breaker must be installed.
2. 100-240VAC rated equipment: A 250VAC appropriately rated circuit breaker must be installed.
3. A circuit breaker is not required for 12, 24 or 48 VDC rated power supplies.
4. Separate circuit breakers must be installed and separately identified.
5. Equipment must be installed according to the applicable country wiring codes.

2.3 HIPOT (Dielectric Strength) Testing

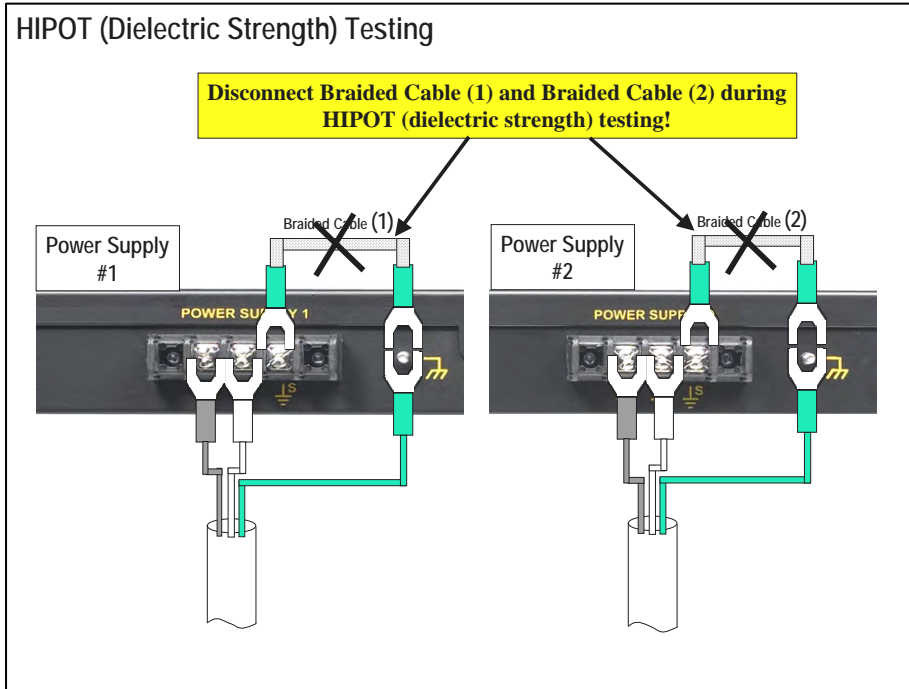

Figure 13: HIPOT (Dielectric Strength) Testing

NOTE: Units which are to be “HIPOT” tested in the field must have the braided ground cable(s) disconnected (see **Figure 13**) during the HIPOT test. This is required in order to prevent the transient/surge suppression circuitry, which is connected to Surge Ground (see **Figure 7**), from being activated during the HIPOT test.

2.4 Failsafe Output Wiring and Specifications

The “Failsafe” output relay is provided to signal critical error conditions that may occur on the RS1600 series switches. The contacts are energized upon power up of the unit and remain energized until a critical error occurs. One common application for this output, regardless of whether the switch is managed or unmanaged, is to signal an alarm if a power failure or removal of control power occurs.

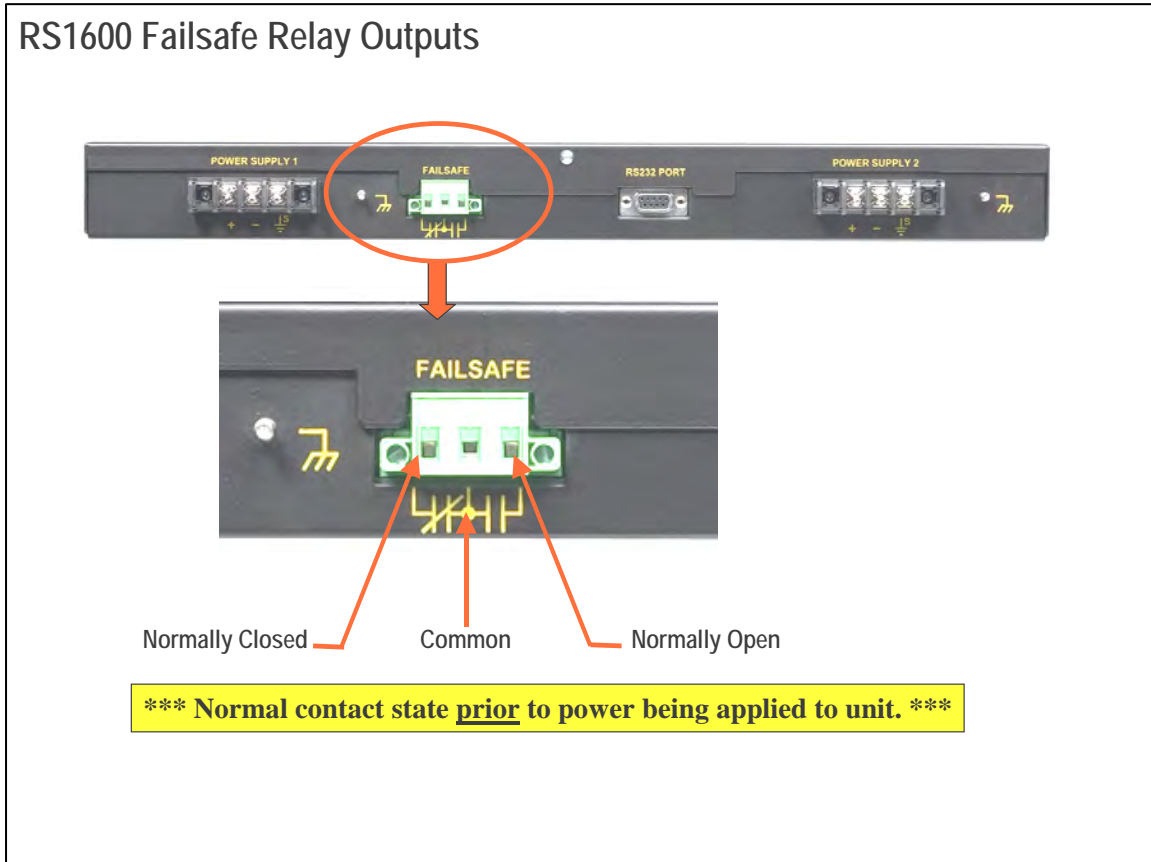

Figure 14: Failsafe Output Relay

2.5 RS232 Port Wiring

The RS232 port is used for configuring the RS1600 / RS1600T when the management CPU is present. The management CPU is present if the order code contains the "MS" option (e.g. RS1600-xx-xx-xx-MS-xx). A straight-through serial cable with a DB-9 connector is required. There is no need to cross-over the TXD and RXD signals from the PC side since this has been done internally as is shown in Figure 15.

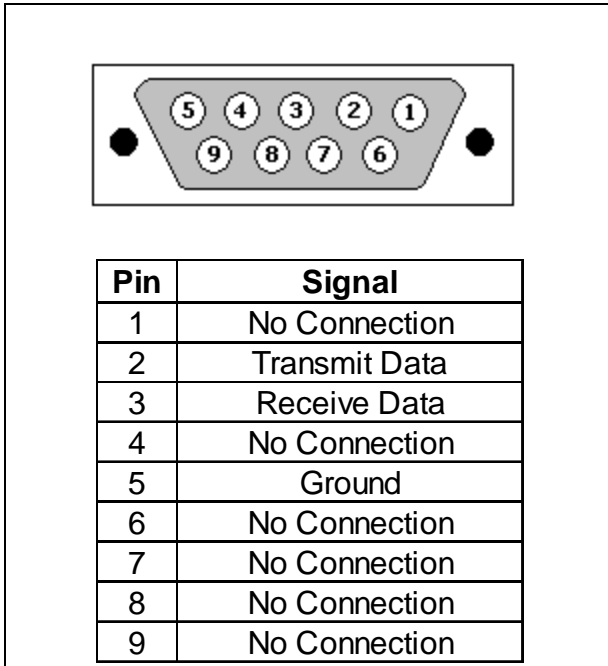

Figure 15: RS232 Port Signals

NOTE: This port is not intended to be a permanent connection and the cable shall be less than 2m (6.5 ft) in length.

2.6 RJ45 Twisted-Pair Data Ports

RS1600 series switches may have 10/100BaseTX ports that allow connection to standard CAT-5 UTP cable with RJ45 male connectors. The RJ45 receptacles are directly connected to the chassis ground on the RS1600 and can accept shielded CAT-5 cables. If shielded cables are used, care must be taken to ensure the shielded cables do not form a ground loop via the shield wire and the RJ45 receptacles at either end.

All RJ45 RuggedSwitch products feature auto-negotiating, auto-polarity, and auto-crossover functions with the exception of the base RS1600 model (port 15 and 16 only). The base RS1600 (RS1600-XX-XX-XX-XX-RJ) is not auto-crossover capable. Figure 16 shows the RJ45 port pins configuration.

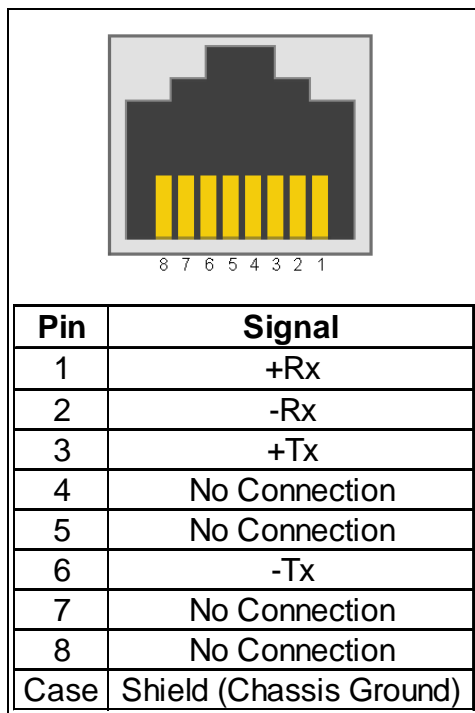

Figure 16 shows the RJ45 port pins configuration

NOTE: RuggedCom does not recommend the use of CAT-5 cabling of any length for critical real-time substation automation applications. However, transient suppression circuitry is present on all copper ports to protect against damage from electrical transients and to ensure IEC 61850-3 and IEEE 1613 Class 1 conformance. This means that during the transient event communications errors or interruptions may occur but recovery is automatic.

RuggedCom also does not recommended to use these ports to interface to field devices across distances which could produce high levels of ground potential rise, (i.e. greater than 2500V) during line to ground fault conditions.

3 Technical Specifications

3.1 Operating Environment

Parameter	Range	Comments
Ambient Operating Temperature	-40 to 85°C	Ambient Temperature as measured from a 30 cm radius surrounding the center of the RS1600 enclosure.
Ambient Relative Humidity	5% to 95%	Non-condensing
Ambient Storage Temperature	-40 to 85°C	

3.2 Power Supply Specifications

Power Supply Type	Input Range		Internal Fuse Rating	Isolation	Max. Power Consumption		
	Min	Max			RS1600	RS1600T	RS1600F
12 – 24 VDC	10 VDC	36 VDC	6.3A(F) ²	1.5 kV DC	30 W	21 W	34 W
24 VDC	18 VDC	36 VDC	5A(F) ²	1.5 kV DC			
48 VDC	36 VDC	59 VDC	2A(T) ²	1.5 kV DC			
HI (125/250 VDC) ¹ HI (110/230 VAC) ¹	88 VDC 85 VAC	300 VDC 265 VAC	2A(T) ^{1,2}	4 kV AC 5.5 kV DC			

NOTES:

1. This is the same power supply for both AC and DC.
2. (F) Denotes fast-acting fuse, (T) denotes time-delay fuse

3.3 Failsafe Relay Specifications

Parameter	Value
Max Switching Voltage	30VAC, 80VDC
Rated Switching Current	0.3A @ 30VAC 1A @ 30VDC, 0.3A @ 80VDC

3.4 Data Port Specifications

Data Port	Media	Distance	Connector Type
10/100 Mbps*	Cat 5 UTP	100m	RJ45

*Available as an option on RS1600

3.5 Fiber Optical Specifications

<i>Speed Standard</i>	<i>Mode / Connector</i>	<i>Tx λ (nm)</i>	<i>Cable Type² (μm)</i>	<i>Tx Pwr (dBm peak)³ (Min / Max)</i>	<i>Rx Sensitivity (dBm Average)³</i>	<i>Rx Saturation (dBm Peak)³</i>	<i>Typical Distance (km)¹</i>	<i>Power Budget (dB)</i>
10BaseFL	MM / ST	820	50/125	-16.5/-10.6	-34.4	-11.2	2	21
100BaseFX	MM / MTRJ	1310	50/125	-16/-11	-33.5	-11	2	17
100BaseFX	SM / LC	1310	9/125	-15/-8	-31	-5	15	16.5

NOTES:

1. Maximum segment length is greatly dependent on factors such as fiber quality, and number of patches and splices. Please consult RuggedCom sales associates when determining maximum segment distances.
2. To convert from average to peak add 3dBm. To convert from peak to average, subtract 3dBm.
3. Single-mode is available as an option.

3.6 Mechanical Specifications

Parameter	Value	Comments
Dimensions	18.29 x 10.17 x 1.74 inches (464,57) x (258,32) x (44,20) mm	(Length x Width x Height) with mounting brackets installed
Weight	10 lb (4.5 Kg)	
Enclosure	18 gauge Galvanized Steel	

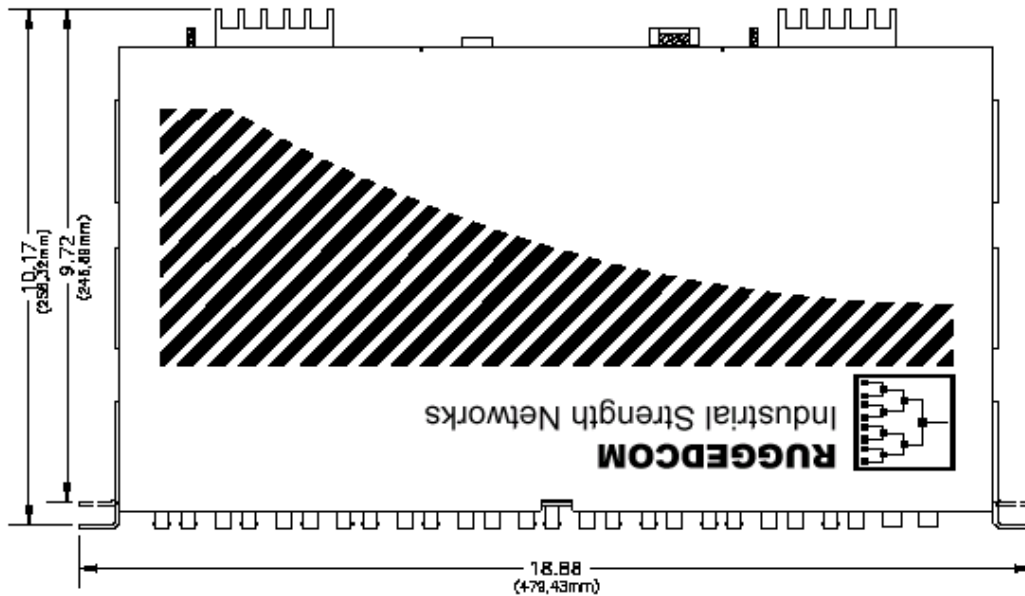
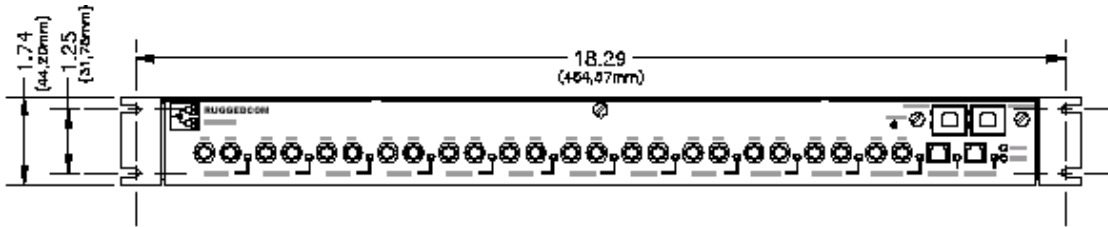

4 Type Tests

4.1 IEC 61850-3 Type Tests

<i>Test</i>	<i>Description</i>		<i>Test Levels</i>	<i>Severity Levels</i>
IEC 61000-4-2	ESD	Enclosure Contact	+/- 8kV	4
		Enclosure Air	+/- 15kV	4
IEC 61000-4-3	Radiated RFI	Enclosure ports	20 V/m	x
IEC 61000-4-4	Burst (Fast Transient)	Signal ports	+/- 4kV @ 2.5kHz	x
		D.C. Power ports	+/- 4kV	4
		A.C. Power ports	+/- 4kV	4
		Earth ground ports	+/- 4kV	4
IEC 61000-4-5	Surge	Signal ports	+/- 4kV line-to-earth, +/- 2kV line-to-line	4
		D.C. Power ports	+/- 2kV line-to-earth, +/- 1kV line-to-line	3
		A.C. Power ports	+/- 4kV line-to-earth, +/- 2kV line-to-line	4
IEC 61000-4-6	Induced (Conducted) RFI	Signal ports	10V	3
		D.C Power ports	10V	3
		A.C. Power ports	10V	3
		Earth ground ports	10V	3
IEC 61000-4-8	Magnetic Field	Enclosure ports	40 A/m continuous, 1000 A/m for 1 s	N/A
IEC 61000-4-29	Voltage Dips & Interrupts	D.C. Power ports	30% for 0.1s, 60% for 0.1s, 100% for 0.05s	N/A
IEC 61000-4-11		A.C. Power ports	30% for 1 period, 60% for 50 periods 100% for 5 periods, 100% for 50 periods ²	N/A
IEC 61000-4-12	Damped Oscillatory	Signal ports	2.5kV common, 1kV differential mode @ 1MHz	3
		D.C. Power ports	2.5kV common, 1kV differential mode @ 1MHz	3
		A.C. Power ports	2.5kV common, 1kV differential mode @ 1MHz	3
IEC 61000-4-16	Mains Frequency Voltage	Signal ports	30V Continuous, 300V for 1s	4
		D.C. Power ports	30V Continuous, 300V for 1s	4
IEC 61000-4-17	Ripple on D.C. Power Supply	D.C. Power ports	10%	3
IEC 60255-5	Dielectric Strength	Signal ports	2kV AC (Fail-Safe Relay output)	N/A
		D.C. Power ports	1.5kV DC	N/A
		A.C. Power ports	2kV AC	N/A
IEC 60255-5	H.V. Impulse	Signal ports	5kV (Fail-Safe Relay output)	N/A
		D.C. Power ports	5kV	N/A
		A.C. Power ports	5kV	N/A

4.2 IEEE 1613 Type Tests

IEEE Test	IEEE 1613 Clause	Description		Test Levels
C37.90.3	9	ESD	Enclosure Contact	+/- 8kV
			Enclosure Air	+/- 15kV
C37.90.2	8	Radiated RFI	Enclosure ports	35 V/m
C37.90.1	7	Fast Transient	Signal ports	+/- 4kV @ 2.5kHz
			D.C. Power ports	+/- 4kV
			A.C. Power ports	+/- 4kV
			Earth ground ports	+/- 4kV
C37.90.1	7	Oscillatory	Signal ports	2.5kV common mode @ 1MHz
			D.C. Power ports	2.5kV common & differential mode @ 1MHz
			A.C. Power ports	2.5kV common & differential mode @ 1MHz
C37.90	6	H.V. Impulse	Signal ports	5 kV (Failsafe Relay)
			D.C. Power ports	5 kV
			A.C. Power ports	5 kV
C37.90	6	Dielectric Strength	Signal ports	2kV AC(Failsafe Relay)
			D.C. Power ports	1.5kV DC
			A.C. Power ports	2kV AC

NOTE:

- If the unit contains copper ports the IEEE 1613 conformance is Class 1 (During disturbance errors may occur but recovery is automatic).
- If the unit contains all fiber ports the IEEE 1613 conformance is Class 2 (During disturbance no errors will occur).

4.3 IEC Environmental Type Tests

Test	Description		Test Levels	Severity Levels
IEC 60068-2-1	Cold Temperature	Test Ad	-40 deg. C, 16 Hours	N/A
IEC 60068-2-2	Dry Heat	Test Bd	+85 deg. C, 16 Hours	N/A
IEC 60068-2-30	Humidity (Damp Heat, Cyclic)	Test Db	95% (non-condensing), 55°C, 6 cycles	N/A
IEC 60255-21-1	Vibration		2g @ (10-150) Hz	Class 2
IEC 60255-21-2	Shock		30g @ 11 ms	Class 2

5 Agency Approvals

<i>Agency</i>	<i>Standards</i>	<i>Comments</i>
CSA	CSA C22.2 No. 60950, UL 60950	Approved
CE	EN 60950, EN 61000-6-2	Approved
FCC	FCC Part 15, Class A	Approved
CISPR	EN55022, Class A	Approved
FDA/CDRH	21 CFR Chapter 1, Subchapter J	Compliant
IEC/EN	EN60825-1:1994 + A11:1996 + A2:2001	Compliant

6 Warranty

RuggedCom warrants this product for a period of five (5) years from date of purchase. For warranty details, visit <http://www.ruggedcom.com/> or contact your customer service representative. Should this product require warranty or service, contact the factory at:

RuggedCom Inc.
300 Applewood Crescent
Concord, Ontario
Canada L4K 5C7

Phone: +1 905 856 5288
Fax: +1 905 856 1995