

RuggedSwitch[®] RS8000 Family

Installation Guide



RuggedCom Inc.
300 Applewood Crescent
Concord, Ontario
Canada L4K 5C7

Web: www.ruggedcom.com
Tel: +1 905 856 5288
Fax: +1 905 856 1995
Toll Free: 1 888 264 0006

Copyright

COPYRIGHT © 2010 RuggedCom Inc. ALL RIGHTS RESERVED

Dissemination or reproduction of this document, or evaluation and communication of its contents, is not authorized except where expressly permitted. Violations are liable for damages. All rights reserved, particularly for the purposes of patent application or trademark registration.

This document contains proprietary information, which is protected by copyright. All rights are reserved. No part of this document may be photocopied, reproduced or translated to another language without the prior written consent of RuggedCom Inc.

Disclaimer of liability

We have checked the contents of this manual against the hardware and software described. However, deviations from the description cannot be completely ruled out.

RuggedCom shall not be liable for any errors or omissions contained herein or for consequential damages in connection with the furnishing, performance, or use of this material.

The information given in this document is reviewed regularly and any necessary corrections will be included in subsequent editions. We appreciate any suggested improvements. We reserve the right to make technical improvements without notice.

Registered Trademarks

RuggedRated™, ROS™ and eRSTP™ are trademarks of RuggedCom Inc. RuggedRouter® and RuggedSwitch® are registered trademarks of RuggedCom Inc. Other designations in this manual might be trademarks whose use by third parties for their own purposes would infringe the rights of the owner.

Contacting RuggedCom

Corporate Headquarters	US Headquarters	Europe Headquarters
RuggedCom Inc. 300 Applewood Crescent Concord, Ontario Canada, L4K 5C7	RuggedCom 1930 Harrison St., Suite 209 Hollywood, Florida USA, 33020	RuggedCom Unit 41, Aztec Centre, Aztec West, Almondsbury, Bristol United Kingdom BS32 4TD
Tel: +1 905 856 5288 Fax: +1 905 856 1995 Toll-free: 1 888 264 0006	Tel: +1 954 922 7938 ext. 103 Fax: +1 954 922 7984 Toll-free: 1 888 264 0006	Tel: +44 1454 203 404 Fax: +44 1454 203 403
Email: RuggedSales@RuggedCom.com		

Technical Support

Toll Free (North America): 1 866 922 7975
International: +1 905 856 5288
Email: Support@RuggedCom.com

Web: www.RuggedCom.com

Federal Communications Commission Radio Frequency Interference Statement

This equipment has been tested and found to comply with the limits for a Class A digital device pursuant to Part 15 of the FCC Rules. These limits are designed to provide reasonable protection against harmful interference when the equipment is operated in a commercial environment. This equipment generates, uses and can radiate radio frequency energy and, if not installed and used in accordance with the instruction manual, may cause harmful interference to radio communications. Operation of this equipment in a residential area is likely to cause harmful interference in which case the user will be required to correct the interference on his own expense.

Warning: Changes or modifications not expressly approved by RuggedCom Inc. could void the user's authority to operate the equipment.

Important:

The RS8000 family of Ethernet switches contains no user-serviceable parts. Attempted service by unauthorized personnel shall render all warranties null and void.

All RS8000 type units should be installed in a **restricted access location** where access can only be gained by service personnel or users who have been instructed about the reasons for the restrictions applied to the location and about any precautions that shall be taken; and access is through the use of a tool or lock and key, or other means of security, and is controlled by the authority responsible for the location.

Table of Contents

1	Product Overview	5
1.1	Functional Overview	5
1.2	Feature Highlights.....	5
1.3	RS8000 Family Overview	6
1.4	RS8000 Family Front Panel Description.....	7
1.5	RS8000 Family Top and Bottom View.....	8
1.6	RS8000 Family Top Views (Other Models).....	9
2	Installation	10
2.1	DIN Rail Mounting.....	10
2.2	Power Supply Wiring and Grounding.....	11
2.2.1	Power Supply - AC Input	12
2.2.2	Power Supply – DC Inputs	12
2.3	HIPOT (Dielectric Strength) Testing	13
2.4	Failsafe Output Wiring and Specifications	14
2.5	RS232 Port Wiring	15
2.6	RJ45 Ports – Signal Description	16
3	Technical Specifications	17
3.1	Power Supply Specifications.....	17
3.2	Failsafe Relay Specifications.....	17
3.3	Twisted Pair Data Port Specifications.....	17
3.4	Fiber Optical Specifications	18
3.5	Operating Environment.....	19
3.6	Physical Dimensions.....	20
4	Type Tests.....	21
4.1	IEC 61850-3 Type Tests.....	21
4.2	IEEE 1613 Type Tests.....	22
4.3	IEC Environmental Type Tests	22
5	Agency Approvals	23
6	Warranty.....	23

1 Product Overview

1.1 Functional Overview

The RuggedSwitch™ RS8000 Family of switches (RS8000X) are substation hardened, fiber optical Ethernet switches specifically designed to operate in harsh environments such as those found in electric utility substations and harsh industrial environments. The RS8000 family provides multiple fiber optical port and speed selections as well as 10/100 RJ45 twisted-pair connectivity as well.

Specifically tested to the same standards as mission critical protective relaying equipment (i.e. ANSI/IEEE C37.90 and IEC 60255), the RS8000X is ideally suited to form the Ethernet network in a UCA2 (Utility Communications Architecture 2.0) based substation automation network. Because the RS8000 series was designed to meet the demands of the substation environment it is also ideally suited for industrial automation networks based on Industrial Ethernet. The reliability of the RS8000X exceeds that of commercial Ethernet switches by having no rotating mechanical parts such as cooling fans and by utilizing high-temperature solid-state components.

1.2 Feature Highlights

- Utility Grade (i.e. substation hardened) per ANSI/IEEE C37.90, IEC 60255, and the new IEC 61850-3 (2002), IEC 61000-6-5 standards
- Operating temperature: -40° to 85°C (no fan)
- Radiated RF Immunity: 35V/m per ANSI/IEEE C37.90.2
- Power supply options: 12, 24 or 48 VDC, and universal HI (88-300VDC or 84-264VAC)
- Failsafe output relay for critical failure or error alarming
- Advanced layer 2 switching functions: 802.1p Message Prioritization, 802.1Q VLAN
- Full-duplex operation (no collisions)

1.3 RS8000 Family Overview

The RS8000 series Ethernet switch is available in several models to provide connectivity to a number of different design topologies and to serve a greater number of end-devices. The models details are shown below. All RS8000 models feature the same power supply options and mechanical dimensions.

RS8000 Family Overview			
Model	Quantity	Ports Type Options and Media	Connector Type
RS8000	8	100BaseFX Multi-mode Fiber	MTRJ
		100BaseFX Single-mode Fiber	LC
RS8000T	2	100BaseFX Multi-mode Fiber	MTRJ
		100BaseFX Single-mode Fiber	LC
	6	Auto-negotiating 10BaseT / 100BaseTx Twisted Pair	RJ45
RS8000A	4	100BaseFX Multi-mode Fiber	MTRJ
		100BaseFX Single-mode Fiber	LC
	2	10BaseFL Multi-mode Fiber	ST
		10BaseFL Single-mode Fiber	ST
2	Auto-negotiating 10BaseT / 100BaseTx Twisted Pair	RJ45	
RS8000H	4	100BaseFX Multi-mode Fiber	SC or ST
		100BaseFX Single-mode Fiber	SC or ST
	4	Auto-negotiating 10BaseT / 100BaseTx Twisted Pair	RJ45

1.4 RS8000 Family Front Panel Description

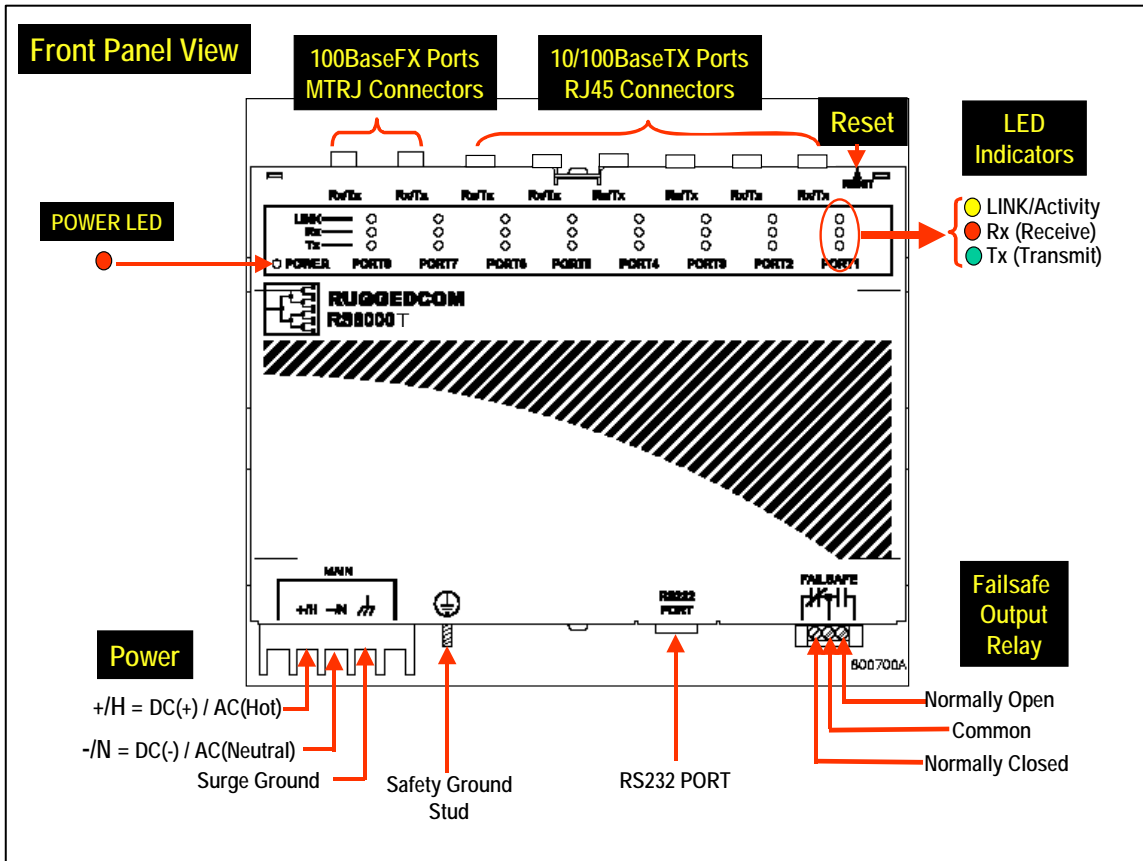

Fig. 1.4.1 RS8000 Family Front Panel Detail (Note: RS8000T Shown)

ITEM	Activity	Comments
LINK LED (Yellow)	Solid	Link Established
	Blinking – Once per second	Tx, Rx Activity
Tx LED (Red)	Blinking	Tx (Transmit) Activity
Rx LED (Green)	Blinking	Rx (Receive) Activity
POWER LED (Red)	Solid	Power On

1.5 RS8000 Family Top and Bottom View

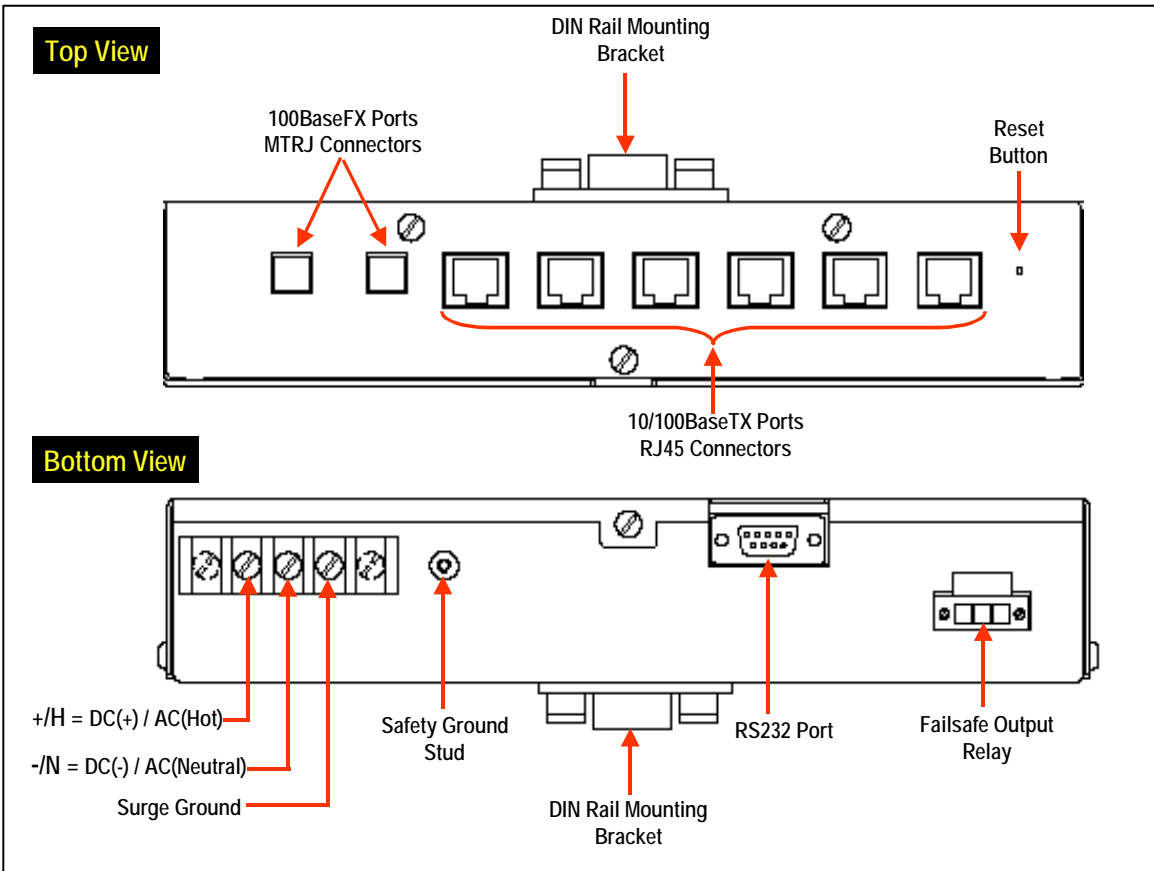

Fig. 1.5.1 RS8000 Family Top and Bottom View (Note: RS8000T Shown)

1.6 RS8000 Family Top Views (Other Models)

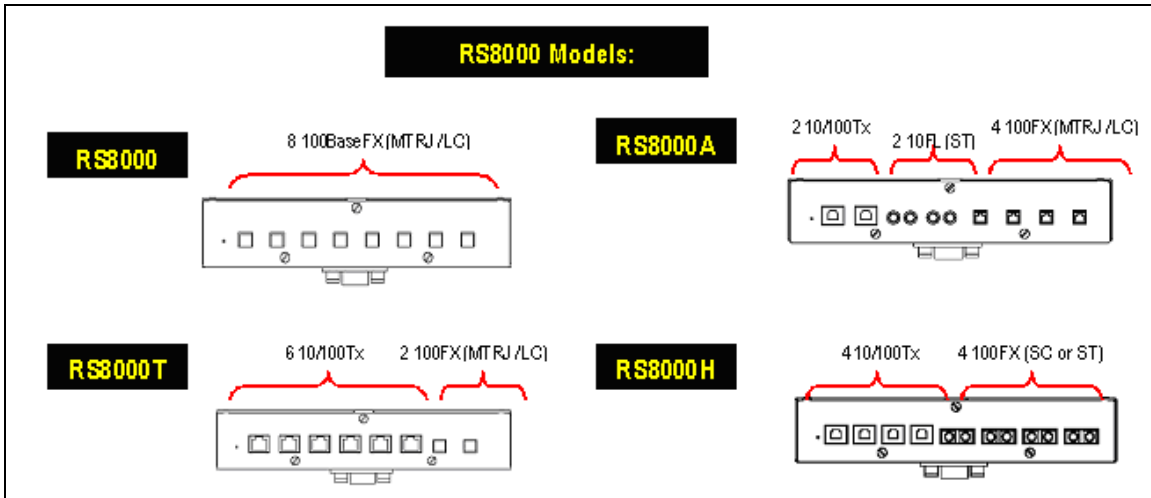

Figure 1.6 Top View of other RS8000 family models

2 Installation

2.1 DIN Rail Mounting

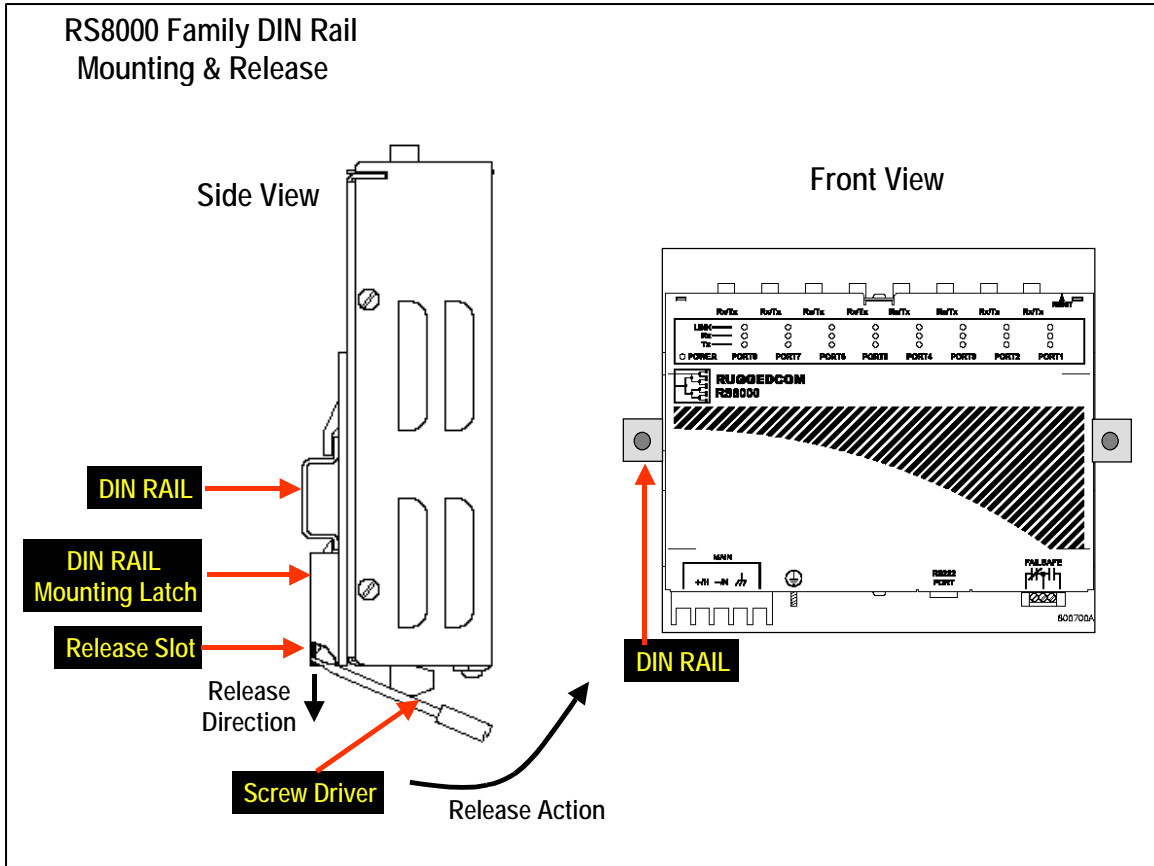

Fig. 2.1.1 RS8000 Family DIN Rail Mounting

2.2 Power Supply Wiring and Grounding

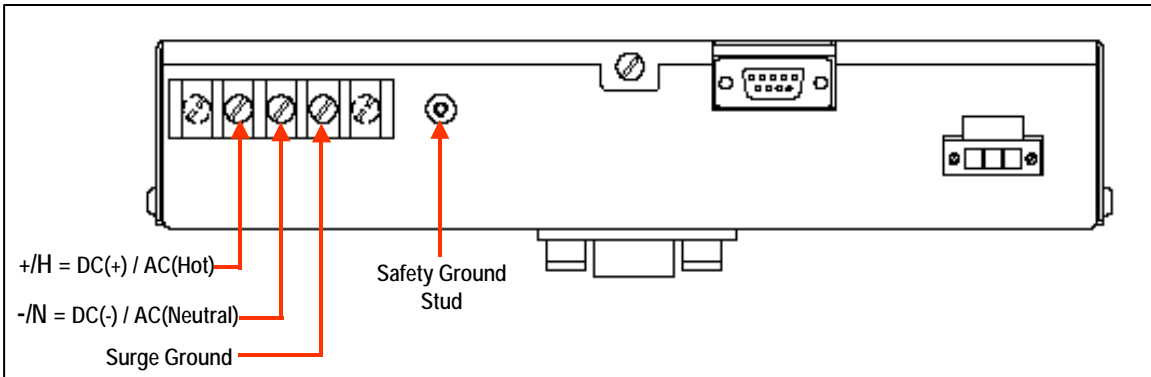

Fig. 2.2.1 RS8000 Family Power Supply Inputs

The RS8000 family power supply inputs are identical and are connected as follows:

1. **+/H = DC (+) / AC (Hot)** is connected to the positive (+) terminal if the power source is DC or to the (Hot) terminal if the power source is AC.
2. **-/N = DC (-) / AC (Neutral)** is connected to the negative (-) terminal if the power source is DC or to the (Neutral) terminal if the power source is AC.
3. **Surge Ground** is connected to the Chassis Ground via a braided cable or other appropriate grounding wire. Surge Ground is used as the ground conductor for all surge and transient suppression circuitry internal to the RS8000 unit. *NOTE: Surge Ground must be disconnected from Chassis Ground during HIPOT (dielectric strength) testing.*
4. **Chassis Ground** is connected to the Safety Ground terminal for AC inputs or the equipment *ground bus* for DC inputs.

Notes:

1. *88-300VDC Equipment: A 300VDC appropriately rated circuit breaker must be installed.*
2. *100-240VAC Equipment: A 250VAC appropriately rated circuit breaker must be installed.*
3. *A circuit breaker is not required for 12, 24 or 48 VDC rated equipment*
4. *Equipment must be installed according to the applicable country wiring codes.*

2.2.1 Power Supply - AC Input

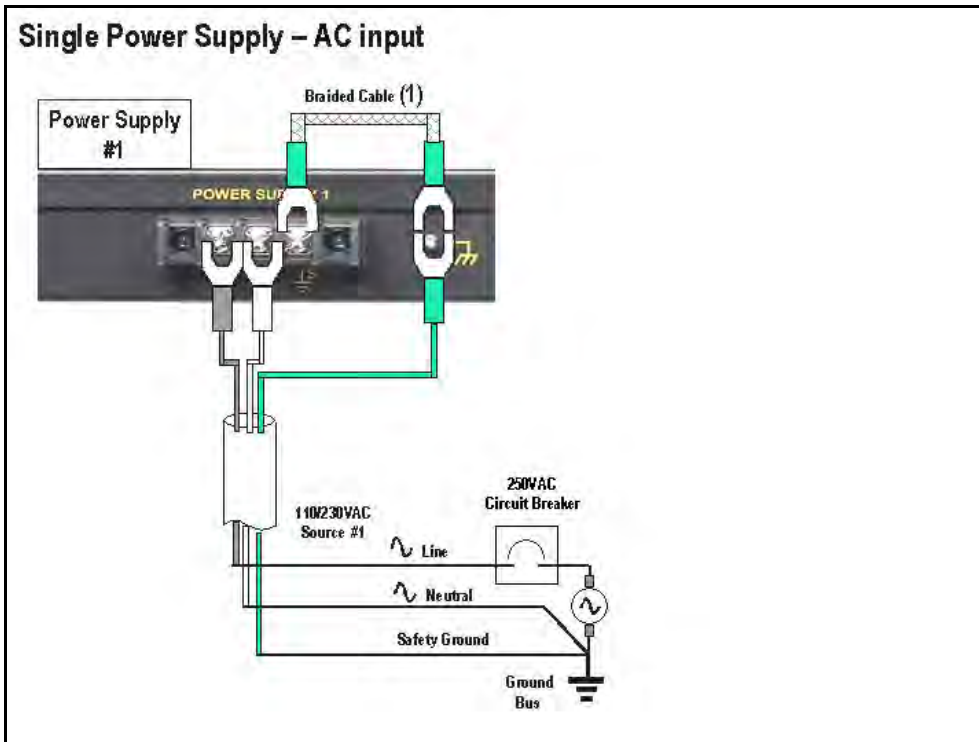

Fig. 2.2.2 Power Supply - AC Input

2.2.2 Power Supply - DC Inputs

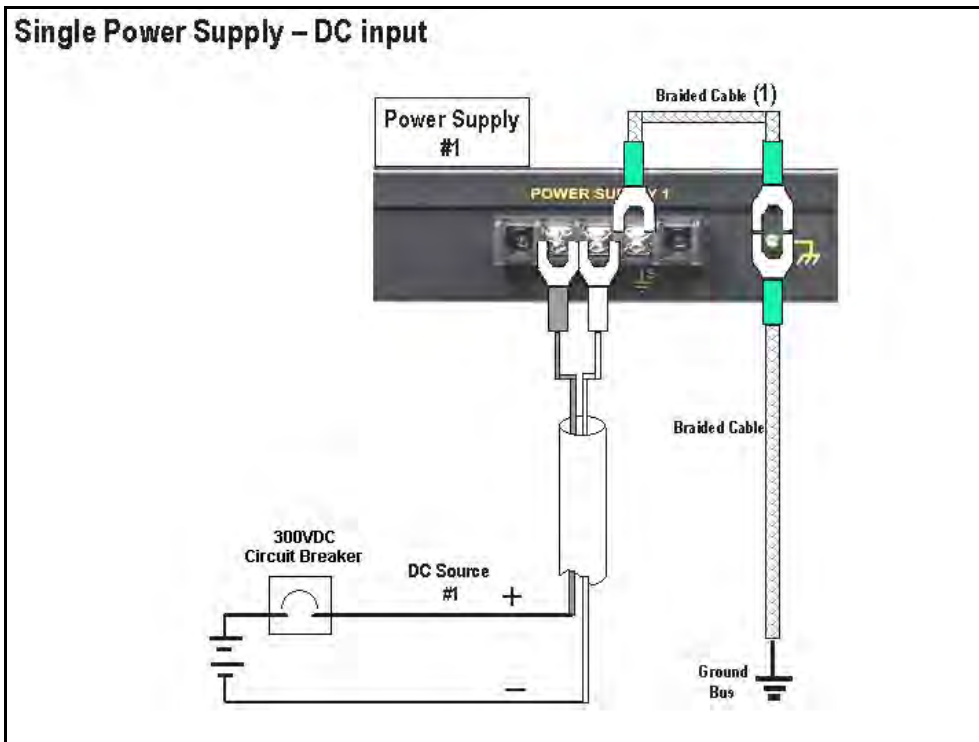

Fig. 2.2.3 Power Supply - DC Inputs

2.3 HIPOT (Dielectric Strength) Testing

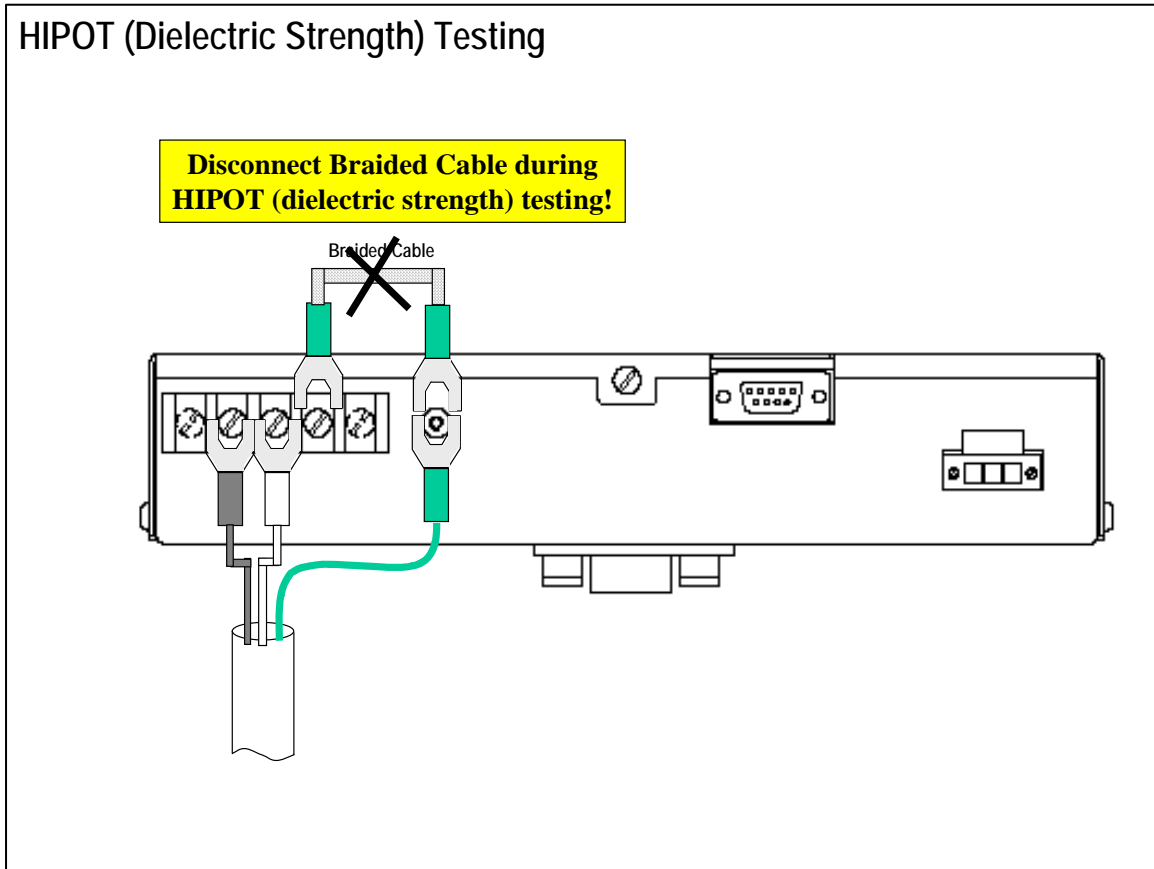

Fig. 2.3.1 HIPOT (Dielectric Strength) Testing

NOTE: Units which are to be "HIPOT" tested in the field must have the braided ground cable(s) disconnected (see Fig. 2.3.1) during the HIPOT test. This is required in order to prevent the transient/surge suppression circuitry, which is connected to Surge Ground (see Fig. 2.2.1), from being activated during the HIPOT test.

2.4 Failsafe Output Wiring and Specifications

The “Failsafe” output relay is provided to signal critical error conditions that may occur on the RS8000 series switch. The contacts are energized upon power up of the unit and remain energized until a critical error occurs. One common application for this output, regardless of whether the switch is managed or unmanaged, is to signal an alarm if a power failure or removal of control power occurs.

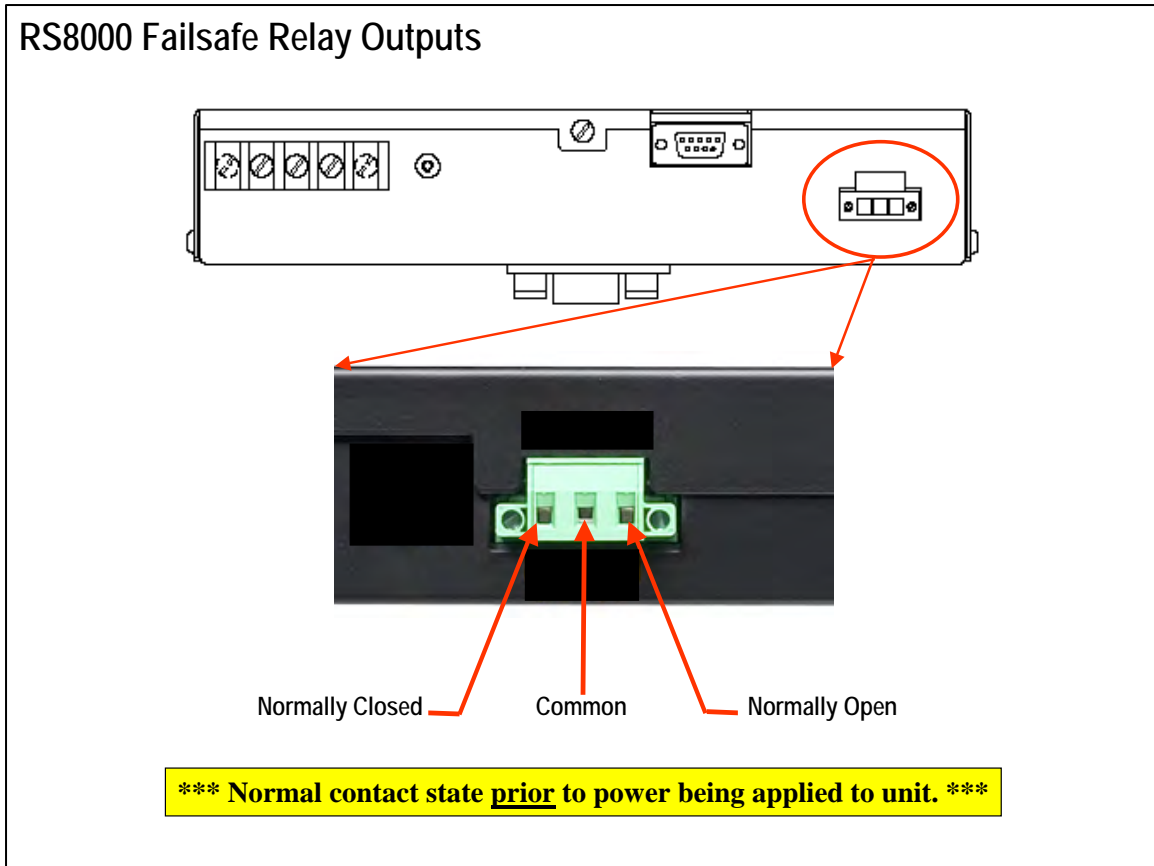

Fig. 2.4.1 RS8000 Family Failsafe Output Relay

2.5 RS232 Port Wiring

The RS232 port is used for configuring the unit. A straight-through serial cable with a DB-9 connector is required. There is no need to crossover the Transmit and Receive signals from the PC side since this has been done internally as shown in the figure below.

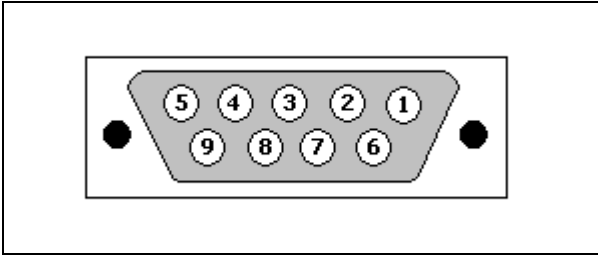

Fig 2.5.1 RS232 Female DCE pin-out

<i>Pin</i>	<i>Signal</i>
1	No Connection
2	Transmit Data
3	Receive Data
4	No Connection
5	Ground
6	No Connection
7	No Connection
8	No Connection
9	No Connection

Table 2.5.1 RS232 Female DCE pin-out

NOTE: This port is not intended to be a permanent connection and the cable shall be less than 2m (6.5 ft) in length.

2.6 RJ45 Ports – Signal Description

Units with 10/100Base-TX ports allow connection to standard Category 5 (CAT-5) unshielded twisted-pair (UTP) cable with RJ45 male connectors. The RJ45 receptacles are directly connected to the chassis ground on the unit and can accept CAT-5 shielded twisted-pair (STP) cables. If shielded cables are used, care must be taken to ensure the shielded cables do not form a ground loop via the shield wire and the RJ45 receptacles at either end. The figure below shows the shows the RJ45 port pin-out and LEDs.

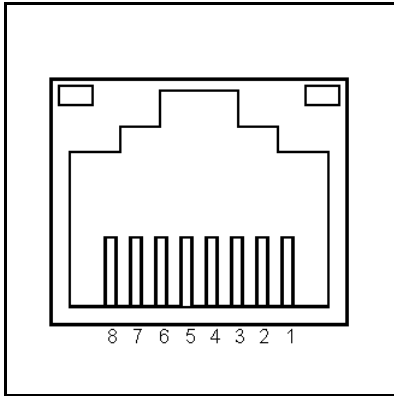

Figure 2.6.1

<i>Pin</i>	<i>Signal</i>
1	+Rx
2	-Rx
3	+Tx
4	No Connection
5	No Connection
6	-Tx
7	No Connection
8	No Connection
Case	Shield (Chassis Ground)

Table 2.6.1

NOTE: RuggedCom does not recommend the use of CAT-5 cabling of any length for critical real-time substation automation applications. However, transient suppression circuitry is present on all copper ports to protect against damage from electrical transients and to ensure IEC 61850-3 and IEEE 1613 Class 1 conformance. This means that during the transient event communications errors or interruptions may occur but recovery is automatic.

RuggedCom also does not recommended to use these ports to interface to field devices across distances which could produce high levels of ground potential rise, (i.e. greater than 2500V) during line to ground fault conditions.

3 Technical Specifications

3.1 Power Supply Specifications

<i>Power Supply Type</i>	<i>Minimum Input</i>	<i>Maximum Input</i>	<i>Internal Fuse Rating</i>	<i>Maximum Power Consumption</i>
12 - 24 VDC	10 VDC	36 VDC	6.3A(F) ²	15 W
24 VDC	18 VDC	36 VDC	5A(F) ²	
48 VDC	36 VDC	59 VDC	3.15A(T) ²	
HI (125/250 VDC) ¹ HI (110/230 VAC) ¹	88 VDC 85 VAC	300 VDC 265 VAC	3.15A(T) ²	

NOTES:

1. This is the same power supply for both AC and DC.
2. (F) Denotes fast-acting fuse, (T) denotes time-delay fuse

3.2 Failsafe Relay Specifications

<i>Parameter</i>	<i>Value</i>
Max Switching Voltage	30VAC, 80VDC
Rated Switching Current	0.3A @ 30VAC 1A @ 30VDC, 0.3A @ 80VDC

3.3 Twisted Pair Data Port Specifications

<i>Data Port</i>	<i>Media</i>	<i>Distance</i>	<i>Connector Type</i>
10/100 Mbps	Cat 5 UTP or STP	100m	RJ45

3.4 Fiber Optical Specifications

<i>Speed Standard</i>	<i>Mode / Connector</i>	<i>Tx λ (nm)</i>	<i>Cable Type² (μm)</i>	<i>Tx Pwr (dBm peak)³ (Min / Max)</i>	<i>Rx Sensitivity (dBm Average)³</i>	<i>Rx Saturation (dBm Peak)³</i>	<i>Typical Distance (km)¹</i>	<i>Power Budget (dB)</i>
10BaseFL	MM / ST	820	50/125	-16.5/-10.6	-34.4	-11.2	2	21
10BaseFL	SM / ST	1310	9/125	-23/-15	-38	-3	15	18
100BaseFX	MM / ST	1310	50/125	-15.7	-33.5	-11	2	17
100BaseFX	MM / SC	1310	50/125	-16/-11	-33	-11	2	17
100BaseFX	MM / MTRJ	1310	50/125	-16/-11	-33.5	-11	2	17
100BaseFX	SM / ST	1310	9/125	-27 / -14	-35	-3	5	8
100BaseFX	SM / SC	1310	9/125	-13/5	-31	-4	20	20
100BaseFX	SM / LC	1310	9/125	-15/-8	-31	-5	15	16.5

Notes:

1. Maximum segment length is greatly dependent on factors such as fiber quality, and number of patches and splices. Please consult RuggedCom sales associates when determining maximum segment distances.
2. To convert from average to peak add 3dBm. To convert from peak to average, subtract 3dBm.
3. Single-mode is available as an option.

3.5 Operating Environment

<i>Parameter</i>	<i>Range</i>	<i>Comments</i>
Ambient Operating Temperature	-40 to 85°C	Ambient Temperature as measured from a 30cm radius surrounding the center of the RS8000 enclosure.
Ambient Relative Humidity	5% to 95%	Non-condensing
Ambient Storage Temperature	-40 to 85°C	

3.6 Physical Dimensions

Parameter	Value	Comments
Dimensions	9.8 x 7.81 x 2.43 inches (242,92) x (195,37) x (61,72) mm	(Length x Width x Height)
Weight	5 lb (2.25 Kg)	
Enclosure	18 gauge Galvanized Steel	

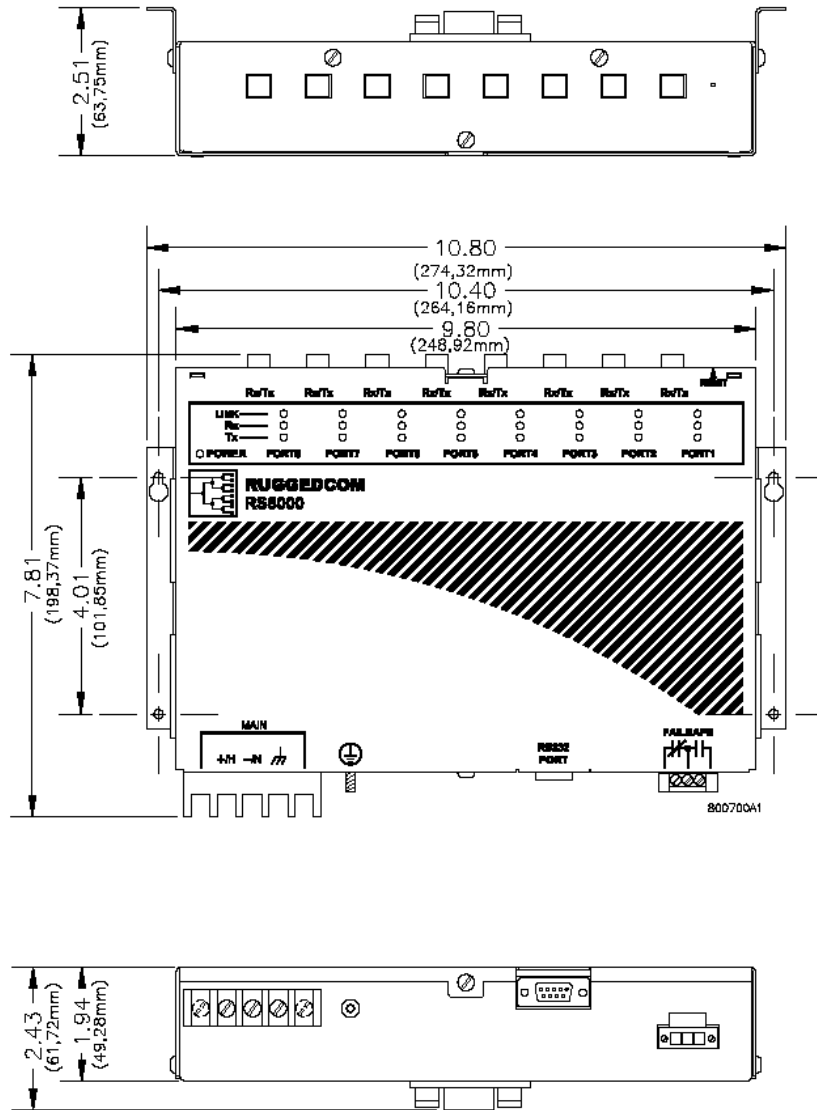

4 Type Tests

4.1 IEC 61850-3 Type Tests

Test	Description		Test Levels	Severity Levels
IEC 61000-4-2	ESD	Enclosure Contact	+/- 8kV	4
		Enclosure Air	+/- 15kV	4
IEC 61000-4-3	Radiated RFI	Enclosure ports	20 V/m	x
IEC 61000-4-4	Burst (Fast Transient)	Signal ports	+/- 4kV @ 2.5kHz	x
		D.C. Power ports	+/- 4kV	4
		A.C. Power ports	+/- 4kV	4
		Earth ground ports	+/- 4kV	4
IEC 61000-4-5	Surge	Signal ports	+/- 4kV line-to-earth, +/- 2kV line-to-line	4
		D.C. Power ports	+/- 2kV line-to-earth, +/- 1kV line-to-line	3
		A.C. Power ports	+/- 4kV line-to-earth, +/- 2kV line-to-line	4
IEC 61000-4-6	Induced (Conducted) RFI	Signal ports	10V	3
		D.C Power ports	10V	3
		A.C. Power ports	10V	3
		Earth ground ports	10V	3
IEC 61000-4-8	Magnetic Field	Enclosure ports	40 A/m continuous, 1000 A/m for 1 s	N/A
IEC 61000-4-29	Voltage Dips & Interrupts	D.C. Power ports	30% for 0.1s, 60% for 0.1s, 100% for 0.05s	N/A
IEC 61000-4-11		A.C. Power ports	30% for 1 period, 60% for 50 periods	N/A
IEC 61000-4-12	Damped Oscillatory	Signal ports	100% for 5 periods, 100% for 50 periods ²	N/A
		D.C. Power ports	2.5kV common, 1kV differential mode @ 1MHz	3
		A.C. Power ports	2.5kV common, 1kV differential mode @ 1MHz	3
IEC 61000-4-16	Mains Frequency Voltage	Signal ports	2.5kV common, 1kV differential mode @ 1MHz	3
		D.C. Power ports	30V Continuous, 300V for 1s	4
IEC 61000-4-17	Ripple on D.C. Power Supply	D.C. Power ports	30V Continuous, 300V for 1s	4
IEC 60255-5	Dielectric Strength	Signal ports	10%	3
		D.C. Power ports	2kV AC (Fail-Safe Relay output)	N/A
		A.C. Power ports	1.5kVDC	N/A
IEC 60255-5	H.V. Impulse	Signal ports	2kVAC	N/A
		D.C. Power ports	5kV (Fail-Safe Relay output)	N/A
		A.C. Power ports	5kV	N/A

Table 1 - IEC 61850-3 Type Tests

4.2 IEEE 1613 Type Tests

IEEE Test	IEEE 1613 Clause	Description		Test Levels
C37.90.3	9	ESD	Enclosure Contact	+/- 8kV
			Enclosure Air	+/- 15kV
C37.90.2	8	Radiated RFI	Enclosure ports	35 V/m
C37.90.1	7	Fast Transient	Signal ports	+/- 4kV @ 2.5kHz
			D.C. Power ports	+/- 4kV
			A.C. Power ports	+/- 4kV
			Earth ground ports	+/- 4kV
C37.90.1	7	Oscillatory	Signal ports	2.5kV common mode @ 1MHz
			D.C. Power ports	2.5kV common & differential mode @ 1MHz
			A.C. Power ports	2.5kV common & differential mode @ 1MHz
C37.90	6	H.V. Impulse	Signal ports	5 kV (Failsafe Relay)
			D.C. Power ports	5 kV
			A.C. Power ports	5 kV
C37.90	6	Dielectric Strength	Signal ports	2kVAC
			D.C. Power ports	1.5kVDC
			A.C. Power ports	2kVAC

Table 2 - IEEE 1613 Type Tests

Notes:

- If the unit contains copper ports, the IEEE 1613 conformance is Class 1 (During disturbance, errors may occur but recovery is automatic).
- If the unit contains all fiber ports, the IEEE 1613 conformance is Class 2 (During disturbance, no errors will occur).

4.3 IEC Environmental Type Tests

Test	Description		Test Levels	Severity Levels
IEC 60068-2-1	Cold Temperature	Test Ad	-40 deg. C, 16 Hours	N/A
IEC 60068-2-2	Dry Heat	Test Bd	+85 deg. C, 16 Hours	N/A
IEC 60068-2-30	Humidity (Damp Heat, Cyclic)	Test Db	95% (non-condensing), 55°C, 6 cycles	N/A
IEC 60255-21-1	Vibration		2g @ (10-150) Hz	Class 2
IEC 60255-21-2	Shock		30g @ 11 ms	Class 2

Table 3 - Environmental Type Tests

Note:

- Class 2 refers to “Measuring relays and protection equipment for which a very high security margin is required or where the vibration levels are very high, (e.g. shipboard application and for severe transportation conditions).”

5 Agency Approvals

<i>Agency</i>	<i>Standards</i>	<i>Comments</i>
CSA, CE	CSA C22.2 No. 60950, UL 60950, EN 60950 EN 61000-6-2	Approved
FCC	FCC Part 15, Class A	Approved
CISPR	EN55022, Class A	Approved

6 Warranty

RuggedCom warrants this product for a period of five (5) years from date of purchase. For warranty details, visit <http://www.ruggedcom.com/> or contact your customer service representative.

Should this product require warranty or service contact the factory at:

RuggedCom Inc.
300 Applewood Crescent
Concord, Ontario
Canada L4K 5C7
Phone: +1 905 856 5288
Fax: +1 905 856 1995