

RuggedSwitch[®] RS940G

8-Port Managed Gigabit Ethernet Switch



Installation Guide

www.ruggedcom.com

Copyright

COPYRIGHT © 2010 RuggedCom Inc. ALL RIGHTS RESERVED

Dissemination or reproduction of this document, or evaluation and communication of its contents, is not authorized except where expressly permitted. Violations are liable for damages. All rights reserved, particularly for the purposes of patent application or trademark registration.

This document contains proprietary information, which is protected by copyright. All rights are reserved. No part of this document may be photocopied, reproduced or translated to another language without the prior written consent of RuggedCom Inc.

Disclaimer of liability

We have checked the contents of this manual against the hardware and software described. However, deviations from the description cannot be completely ruled out.

RuggedCom shall not be liable for any errors or omissions contained herein or for consequential damages in connection with the furnishing, performance, or use of this material.

The information given in this document is reviewed regularly and any necessary corrections will be included in subsequent editions. We appreciate any suggested improvements. We reserve the right to make technical improvements without notice.

Registered Trademarks

RuggedRated™, ROS™ and eRSTP™ are trademarks of RuggedCom Inc. RuggedRouter® and RuggedSwitch® are registered trademarks of RuggedCom Inc. Other designations in this manual might be trademarks whose use by third parties for their own purposes would infringe the rights of the owner.

Contacting RuggedCom

Corporate Headquarters	US Headquarters	Europe Headquarters
RuggedCom Inc. 300 Applewood Crescent Concord, Ontario Canada, L4K 5C7	RuggedCom 1930 Harrison St., Suite 209 Hollywood, Florida USA, 33020	RuggedCom Unit 41, Aztec Centre, Aztec West, Almondsbury, Bristol United Kingdom BS32 4TD
Tel: +1 905 856 5288 Fax: +1 905 856 1995 Toll-free: 1 888 264 0006	Tel: +1 954 922 7938 ext. 103 Fax: +1 954 922 7984 Toll-free: 1 888 264 0006	Tel: +44 1454 203 404 Fax: +44 1454 203 403
Email: RuggedSales@RuggedCom.com		

Technical Support

Toll Free (North America): 1 866 922 7975
International: +1 905 856 5288
Email: Support@RuggedCom.com

Web: www.RuggedCom.com

Federal Communications Commission Radio Frequency Interference Statement

This equipment has been tested and found to comply with the limits for a Class A digital device pursuant to Part 15 of the FCC Rules. These limits are designed to provide reasonable protection against harmful interference when the equipment is operated in a commercial environment. This equipment generates, uses and can radiate radio frequency energy and, if not installed and used in accordance with the instruction manual, may cause harmful interference to radio communications. Operation of this equipment in a residential area is likely to cause harmful interference in which case the user will be required to correct the interference at his expense.

Caution

This product contains a laser system and is classified as a "CLASS 1 LASER PRODUCT".

Use of controls or adjustments or performance of procedures other than those specified herein may result in hazardous radiation exposure. This product contains no user-serviceable parts. Attempted service by unauthorized personnel shall render all warranties null and void.

Should this device require service see the "Warranty" section of this installation guide.

Important

This unit should be installed in a restricted access location where access can only be gained by service personnel or users who have been instructed about the reasons for the restrictions applied to the location and about any precautions that shall be taken; and access is through the use of a tool or lock and key, or other means of security, and is controlled by the authority responsible for the location.

Table of Contents

1	Product Overview	6
1.1	<i>Functional Overview</i>	6
1.2	<i>Feature Highlights</i>	6
1.3	<i>RS940G Front Panel Description.....</i>	7
1.4	<i>RS940G Bottom Panel Description</i>	8
2	Installation.....	9
2.1	<i>Din Rail Mounting.....</i>	9
2.2	<i>Power Supply Wiring and Grounding</i>	10
2.3	<i>Failsafe Output Wiring.....</i>	13
2.4	<i>RS232 Console Port Wiring</i>	14
2.5	<i>Gigabit Ethernet</i>	15
2.6	<i>Ethernet Panel Description</i>	18
3	Technical Specifications	20
3.1	<i>Operating Environment</i>	20
3.2	<i>Power Supply Specifications</i>	20
3.3	<i>Failsafe Relay Specifications</i>	20
3.4	<i>Networking Standards Supported.....</i>	21
3.5	<i>Twisted-Pair Port Specifications.....</i>	21
3.6	<i>Mechanical Specifications.....</i>	21
4	Type Tests.....	23
4.1	<i>IEC 61850-3 Type Tests</i>	23
4.2	<i>IEEE 1613 Type Tests</i>	24
4.3	<i>IEC Environmental Type Tests.....</i>	24
5	Warranty	25

Table of Figures

Figure 1 - RS940G Front Panel Description	7
Figure 2 - RS940G Bottom Panel Description.....	8
Figure 3 - RS940G DIN Rail Mounting	9
Figure 4 - RS940G Power Supply Inputs	10
Figure 5 - DC Power supply wiring and grounding diagram	11
Figure 6 - Dielectric Strength Testing.....	12
Figure 7 - RS940G Failsafe Output Relay	13
Figure 8 - RS232 DCE pin-out.....	14
Figure 9: 1000LX SFP (mini-GBIC) Module and LC connector	16
Figure 10: 1000LX SC connector	16
Figure 11: 1000LX LC connector.....	16
Figure 12: SFP Bail Latch location	18
Figure 13: SFP Removal	18
Figure 14: Copper Port LED Description	18
Figure 15: Fiber Port LED Description.....	18
Figure 16 - Mechanical Specifications	22

Table of Tables

Table 1 - Status LEDs.....	7
Table 2: Cabling categories and 1000BaseTx compliance defined.....	15
Table 3 – RJ45 Ethernet port 9 LED description	19
Table 4 - Operating Environment.....	20
Table 5 - Power Supply Specifications.....	20
Table 6 - Failsafe Relay Specifications.....	20
Table 7- Networking Standards Supported	21
Table 8- Twisted-Pair Port Specifications.....	21
Table 9 - Mechanical Specifications.....	21
Table 10 - IEC 61850-3 Type Tests	23
Table 11 - IEEE 1613 Type Tests.....	24
Table 12 - Environmental Type Tests.....	24

1 Product Overview

1.1 Functional Overview

The RuggedSwitch™ RS940G is an industrially hardened, fully managed Ethernet switch providing six or eight ports of Gigabit Ethernet. Six 10/100/1000BaseTX triple speed copper ports are standard. An additional two copper ports or two fiber ports can be added.

1.2 Feature Highlights

- Ethernet Ports
 - 6 - 10/100/1000BaseTX Triple Speed Copper Ports Standard
 - Optional 2 additional 1000LX SFP Pluggable Gigabit Fiber or 2 additional 10/100/1000BaseTX Copper Ports
 - Bi-directional singlestrand fiber support
 - Long haul optics allow Gigabit distances up to 70km

1.3 RS940G Front Panel Description

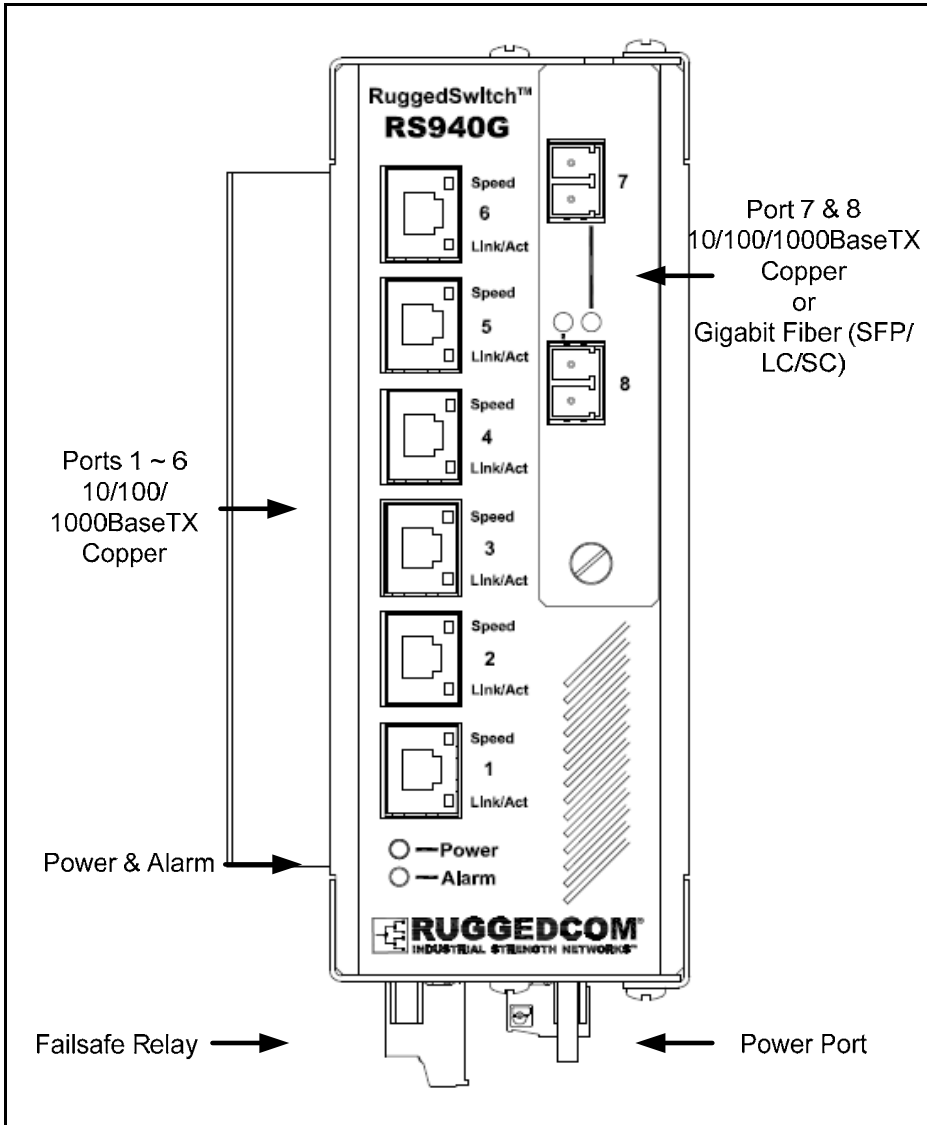

Figure 1 - RS940G Front Panel Description

<i>Status LED</i>	<i>Colour</i>	<i>Activity</i>	<i>Comments</i>
Power LED	Green	Solid	Power On
Alarm LED	Red	Solid	Alarm condition exists

Table 1 - Status LEDs

1.4 RS940G Bottom Panel Description

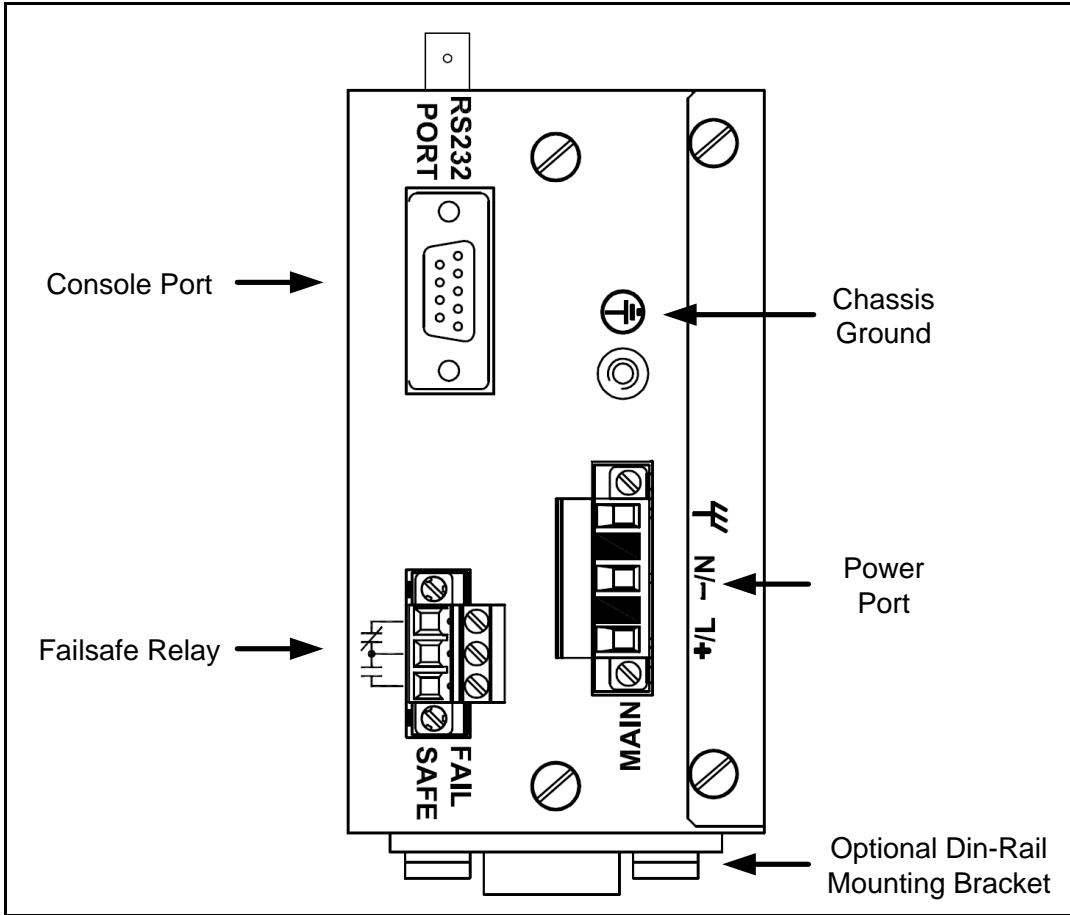

Figure 2 - RS940G Bottom Panel Description

2 Installation

2.1 Din Rail Mounting

An optional DIN rail mounting bracket is available for the RS940G. The figure below details mounting instructions for the standard 1" DIN Rail.

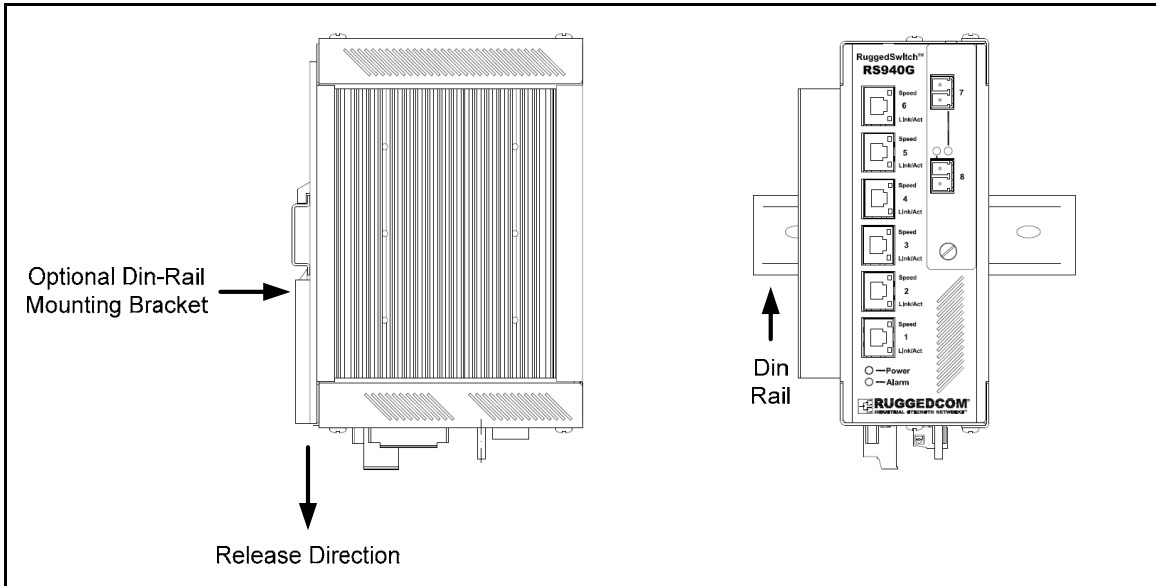

Figure 3 - RS940G DIN Rail Mounting

2.2 Power Supply Wiring and Grounding

2.2.1 AC Power Supply Wiring and Grounding

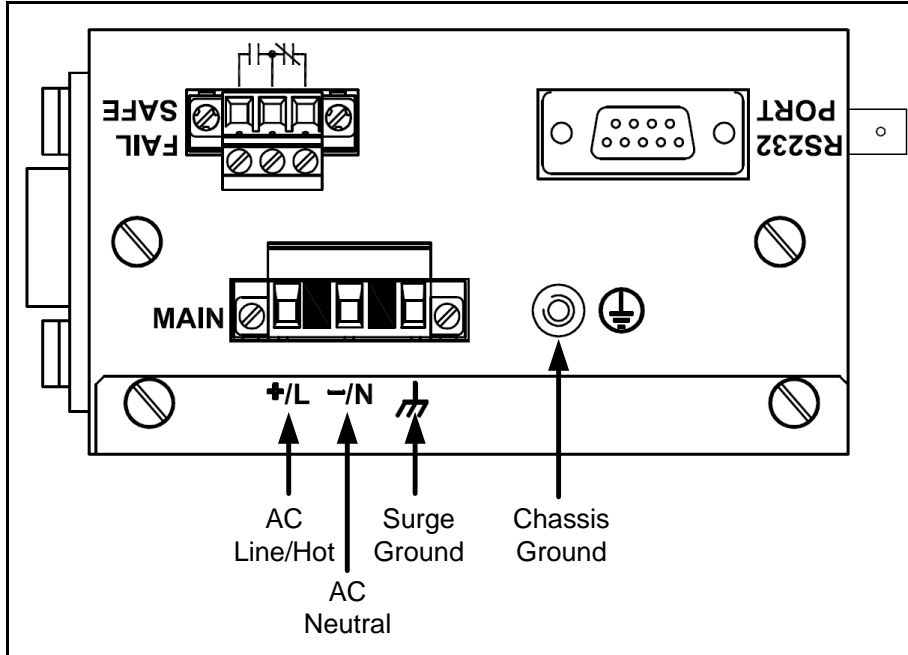

Figure 4 - RS940G Power Supply Inputs

The RS940G AC power supply inputs should be connected as follows:

1. +/L should be connected to AC Line/Hot.
2. -/N should be connected to AC Neutral.
3. Surge Ground should be connected to the Chassis Ground via a braided cable or other appropriate grounding wire. Surge Ground is used as the ground conductor for all surge and transient suppression circuitry internal to the unit.
4. Chassis Ground must be connected to the AC ground terminal.

NOTES:

1. Equipment must be installed according to the applicable country wiring codes.
2. All line-to-ground transient energy is shunted to the Surge Ground terminal. In cases where users require the inputs to be isolated from ground, remove the ground braid between Surge and Chassis Ground. Note that all line-to-ground transient protection circuitry will be disabled.

2.2.2 DC Power Supply Wiring and Grounding

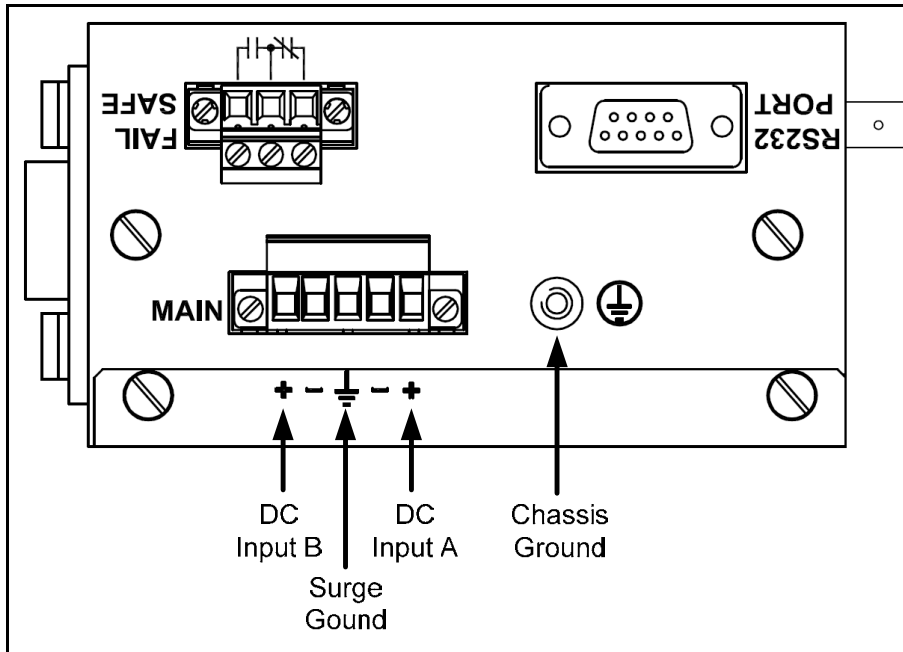

Figure 5 - DC Power supply wiring and grounding diagram

The RS940G low voltage DC power supply features reverse polarity protection and dual independent inputs. The latter feature allows the connection of two DC sources with the same nominal voltage to provide redundant power supply inputs.

The RS940G DC power supply inputs should be connected as follows:

1. Connect to the DC inputs according to the polarity markings on the unit.
2. Surge Ground should be connected to the Chassis Ground via a braided cable or other appropriate grounding wire. Surge Ground is used as the ground conductor for all surge and transient suppression circuitry internal to the unit.
3. Chassis Ground must be connected to the protective earth.

NOTES:

1. Equipment must be installed according to the applicable country wiring codes.
2. All line-to-ground transient energy is shunted to the Surge Ground terminal. In cases where users require the inputs to be isolated from ground, remove the ground braid between Surge and Chassis Ground. Note that all line-to-ground transient protection circuitry will be disabled.

2.2.3 Dielectric Strength Testing

Units which are to have dielectric strength testing (HIPOT testing) done in the field must have the braided ground cable disconnected during the test. This is required in order to prevent the surge suppression circuitry, which is connected to surge ground, from being activated.

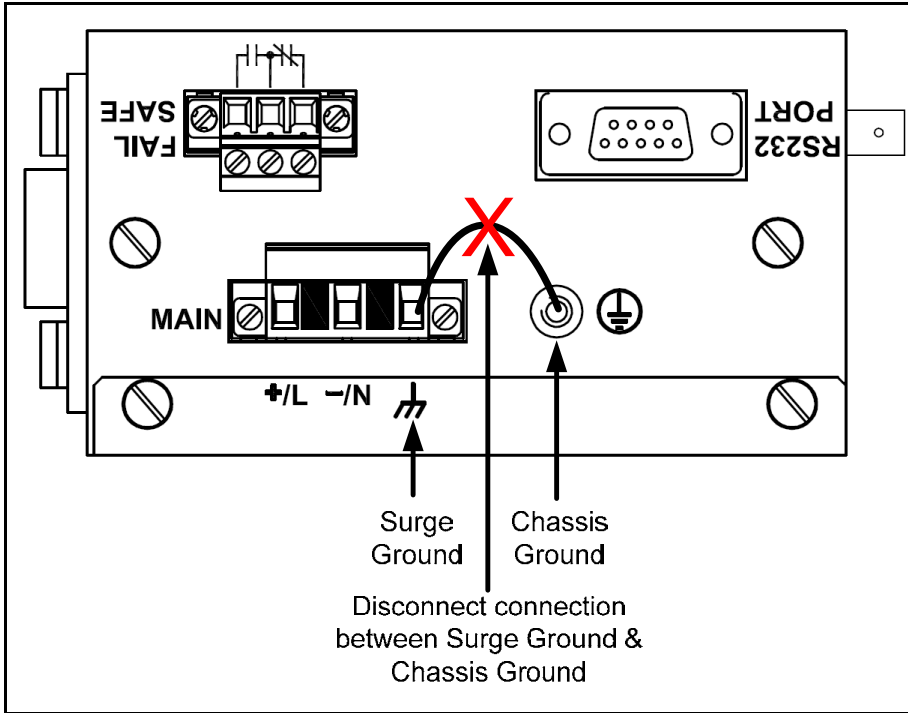

Figure 6 - Dielectric Strength Testing

2.3 Failsafe Output Wiring

The Failsafe output relay is provided to signal critical error conditions that may occur on the RS940G. The contacts are energized upon power up of the unit and remain energized until an alarm condition or power loss occurs. The behavior of the failsafe relay is configurable via the RuggedSwitch Operating System. Consult the RuggedSwitch Users Guide for details.

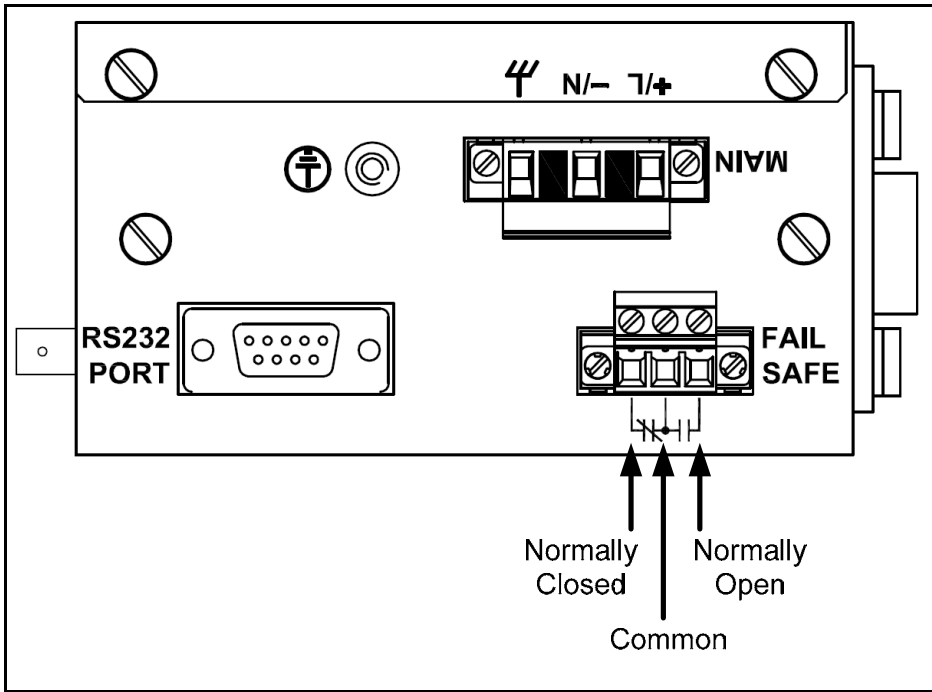

Figure 7 - RS940G Failsafe Output Relay

2.4 RS232 Console Port Wiring

The RS232 port is used for configuring the RS940G. A straight-through serial cable with a DB-9 connector is required. There is no need to crossover the TxD and RxD signals from the PC side since this has been done internally as is shown in the figure below.

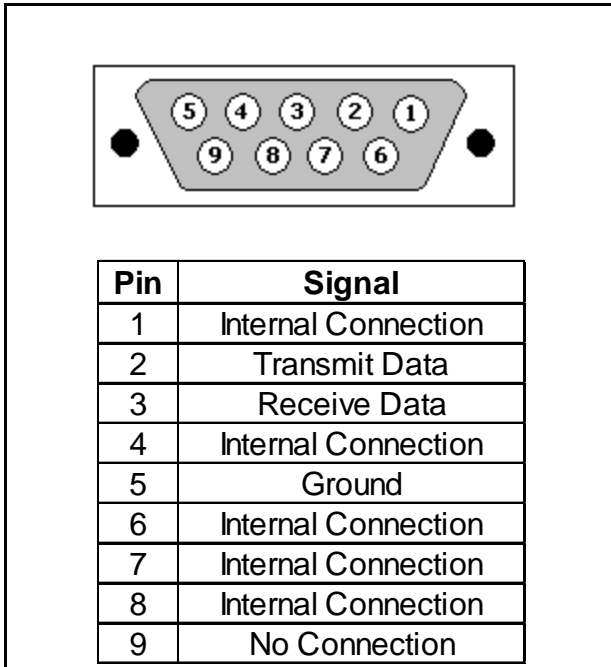

Figure 8 - RS232 DCE pin-out

NOTE: This port is not intended to be a permanent connection and the cable length should not exceed 2m (6.5 feet). Pins 1,4,6 are connected internally, and pins 7, 8 are connected internally.

2.5 Gigabit Ethernet

2.5.1 Copper Gigabit Ethernet 1000Base-TX Cabling Recommendations

The IEEE 802.3ab Gigabit Ethernet standard defines 1000 Mbit/s Ethernet communications over distances of up to 100 meters using 4 pairs of category 5 (or higher) balanced unshielded twisted-pair cabling. For wiring guidelines, system designers and integrators should refer to the Telecommunications Industry Association (TIA) TIA/EIA-568-A wiring standard that characterizes minimum cabling performance specifications required for proper Gigabit Ethernet operation. To ensure reliable, error-free data communications, new and pre-existing communication paths should be verified for TIA/EIA-568-A compliance. Table 2 summarizes cabling standards available today

<i>Cabling Category</i>	<i>1000BaseTx Compliant</i>	<i>Required action</i>
< 5	No	New wire infrastructure required
5	Yes	Verify TIA/EIA-568-A compliance
5e	Yes	No action required. New installations should be designed with Category 5e components or higher
6	Yes	No action required
> 6	Yes	Connector and cabling standards to be determined.

Table 2: Cabling categories and 1000BaseTx compliance defined.

In general the following recommendations should be followed for copper data cabling in high electrical noise environments:

- Data cable lengths should be as short as possible, ideally limited to 3m (10ft) in length. Copper data cables should not be used for inter-building communications.
- Power and data cables should not be run in parallel for long distances, and ideally should be installed in separate conduits. Power and data cables should intersect at 90° angles when necessary to reduce inductive coupling.
- Shielded/screened cabling can optionally be used. The cable shield should be grounded at one single point to avoid the generation of ground loops.

NOTE: RuggedCom does not recommend the use of copper cabling of any length for critical real-time substation automation applications. However, transient suppression circuitry is present on all copper ports to protect against damage from electrical transients and to ensure IEC 61850-3 and IEEE 1613 Class 1 conformance. This means that during the transient event communications errors or interruptions may occur but recovery is automatic. RuggedCom also does not recommended to use these ports to interface to field devices across distances which could produce high levels of ground potential rise, (i.e. greater than 2500V) during line to ground fault conditions.

2.5.2 Fiber Optical Transceiver

Depending on the order code of the product, the RS940G can be equipped with several different types of fiber optic ports. The Transmit (TX) and Receive (RX) connections of each port must be properly connected and matched for proper link and operation.

The drawings in the following figures show each fiber optical connector style with a side and top view to allow the user to identify the proper cable connection orientation.

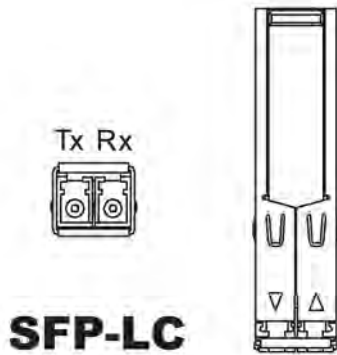

Figure 9: 1000LX SFP (mini-GBIC) Module and LC connector

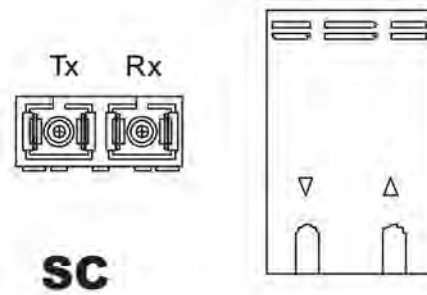

Figure 10: 1000LX SC connector

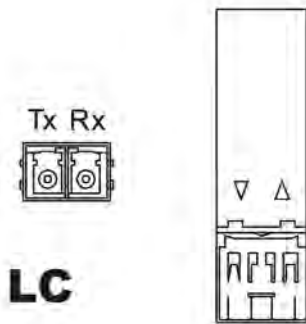

Figure 11: 1000LX LC connector

2.5.3 Pluggable optics – Installation, removal, and precautions

The RS940G can be ordered with pluggable optic form factors such as SFP (Small Form-factor Pluggable). These modules can be safely inserted and removed while the chassis is powered and operating – this feature is also known as “hot-swappable”. When inserting or removing optics there are several precautions that should be taken. They include:

- Ensuring that dust caps are mounted on SFP cages at all times unless a user is in the process of inserting or removing an SFP module. The dust caps will prevent the accumulation of residue or particles that may inhibit proper operation.
- Ensuring that the user has properly discharged any possible electrostatic build-up and electrostatic discharges (ESD). This can be accomplished by properly user ‘grounding’ via an ESD wrist strap, or by touching earth or chassis ground before performing installation or removal of optics. ESD can damage or shorten the life of optical modules when not plugged into a chassis.
- SFP and GBIC optical modules should always be stored in an ESD safe bag or other suitable ESD safe environment, free from moisture and stored at proper storage temperature (–40 to +85°C).
- Disconnect all cables from SFP or GBIC module before insertion or removal of module.
- Only RuggedCom Inc. certified optics should be used on RuggedCom products. Damage can occur to optics and product if compatibility and reliability have not been properly assessed.

2.5.4 Module Insertion – SFPs

To insert SFPs, special attention should be taken into the proper module orientation. SFPs should be inserted with dust cover in place, and the bail-latch in the locked position. Module should gently slide into port and should lock in place when module is fully inserted. To protect optics, dust covers should always be installed when cables are not connected.

2.5.5 SFP Module Removal

SFP Modules are removed using the metal bail latch located on the top of the module shown in **Figure 12**. To remove the SFP module, disconnect any cable and replace with dust cover to protect the optics. User should grasp bail latch and gently pull outwards to unlock and remove the SFP module. Removal of the SFP module is shown further in **Figure 13**. The module should be immediately stored in an ESD-safe environment.



Figure 12: SFP Bail Latch location

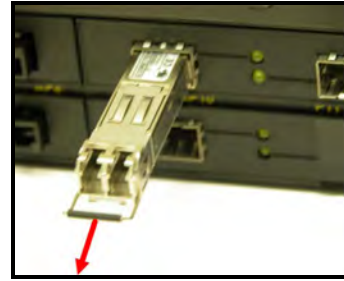

Figure 13: SFP Removal

2.6 Ethernet Panel Description

Each copper Ethernet port, is equipped with two built-in LED that indicates speed and link/activity status information. The speed LED will be on for ports that are operating in 1000BaseTX mode, and off for ports operating in 10/100BaseTX mode. The link/activity LED will be solid for ports with link, and will blink for activity. The diagram in Figure 14 highlights the port and the associated speed and link/activity LED.

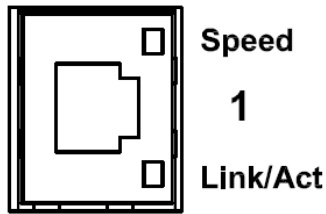

Figure 14: Copper Port LED Description

Each copper Ethernet port, is equipped with one LED that indicates link/activity status information. The LED will be solid for ports with link, and will blink for activity. The diagram in Figure 15 highlights the port and the associated link/activity LED.

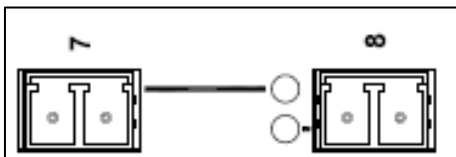

Figure 15: Fiber Port LED Description

<i>Status LED</i>	<i>Colour</i>	<i>Activity</i>	<i>Comments</i>
Speed LED	Yellow	Off	10/100 Mbps
		On	1000 Mbps

Link/Act LED	Yellow	Solid	Link Established
		Blinking	Tx/Rx Activity

Table 3 – RJ45 Ethernet port 9 LED description

3 Technical Specifications

3.1 Operating Environment

<i>Parameter</i>	<i>Range</i>	<i>Comments</i>
Ambient Operating Temperature	-40 to 85°C	Ambient Temperature as measured from a 30 cm radius surrounding the center of the RS940G enclosure.
Ambient Storage Temperature	-40 to 85°C	
Ambient Relative Humidity	5% to 95%	Non-condensing

Table 4 - Operating Environment

3.2 Power Supply Specifications

<i>Power Supply Type</i>	<i>Minimum Input</i>	<i>Maximum Input</i>	<i>Internal Fuse Rating</i>	<i>Isolation</i>	<i>Maximum Power Consumption</i>
12 – 24 VDC	9 VDC	36 VDC	3.15 (T)	1.5 kV DC	18W
24 VDC	18 VDC	36 VDC	3.15 (T)	1.5 kV DC	
48 VDC	36 VDC	59 VDC	3.15 (T)	1.5 kV DC	
HI (125/250 VDC) 1	88 VDC	300 VDC	2 (T)	4 kV AC 5.5 kV DC	
HI (110/230 VAC) 1	85 VAC	265 VAC			

Table 5 - Power Supply Specifications

NOTES:

1. This is the same power supply for both AC and DC.
2. (F) Denotes fast-acting fuse, (T) denotes time-delay fuse.

3.3 Failsafe Relay Specifications

<i>Load Circuit</i>	<i>SELV</i>		<i>TNV-2</i>
MAX operating Voltage	30VDC	30 VAC	80VDC
MAX operating Current	1A	0.5A	0.3A
Isolation (between coil and contacts)	1800 V _{rms}		

Table 6 - Failsafe Relay Specifications

3.4 Networking Standards Supported

<i>Parameter</i>	<i>10Mbps Ports</i>	<i>100Mbps Ports</i>	<i>1000Mbps Ports</i>	<i>Notes</i>
IEEE 802.3				10BaseT / 10BaseFL
IEEE 802.3u				100BaseTX / 100BaseFX
IEEE 802.3z			✓	1000BaseSX/LX
IEEE 802.3ab			✓	1000BaseTx
IEEE 802.3x	✓	✓	✓	Full Duplex Operation
IEEE 802.1D	✓	✓	✓	MAC Bridges
IEEE 802.1Q	✓	✓	✓	VLAN (Virtual LAN)
IEEE 802.1p	✓	✓	✓	Priority Levels

Table 7- Networking Standards Supported

3.5 Twisted-Pair Port Specifications

<i>Parameter</i>	<i>Specification</i>	<i>Notes</i>
Speed	10/100/1000 Mbps	Auto-negotiating
Duplex	FDX / HDX	Auto-negotiating
Cable-Type	> Category 5	Shielded/Unshielded
Wiring Standard	TIA/EIA T568A/B	Auto-Crossover, Auto-polarity
Max Distance	100m	
Connector	RJ45	
Isolation	1.5kV	RMS 1-minute

Table 8- Twisted-Pair Port Specifications

3.6 Mechanical Specifications

<i>Parameter</i>	<i>Value</i>
Dimensions	16.8 x 11.7 x 6.6 cm / 6.6 x 4.6 x 2.6 inches
Weight	1.2 kg / 2.7 lbs
Enclosure	20 AWG Galvanized Steel

Table 9 - Mechanical Specifications

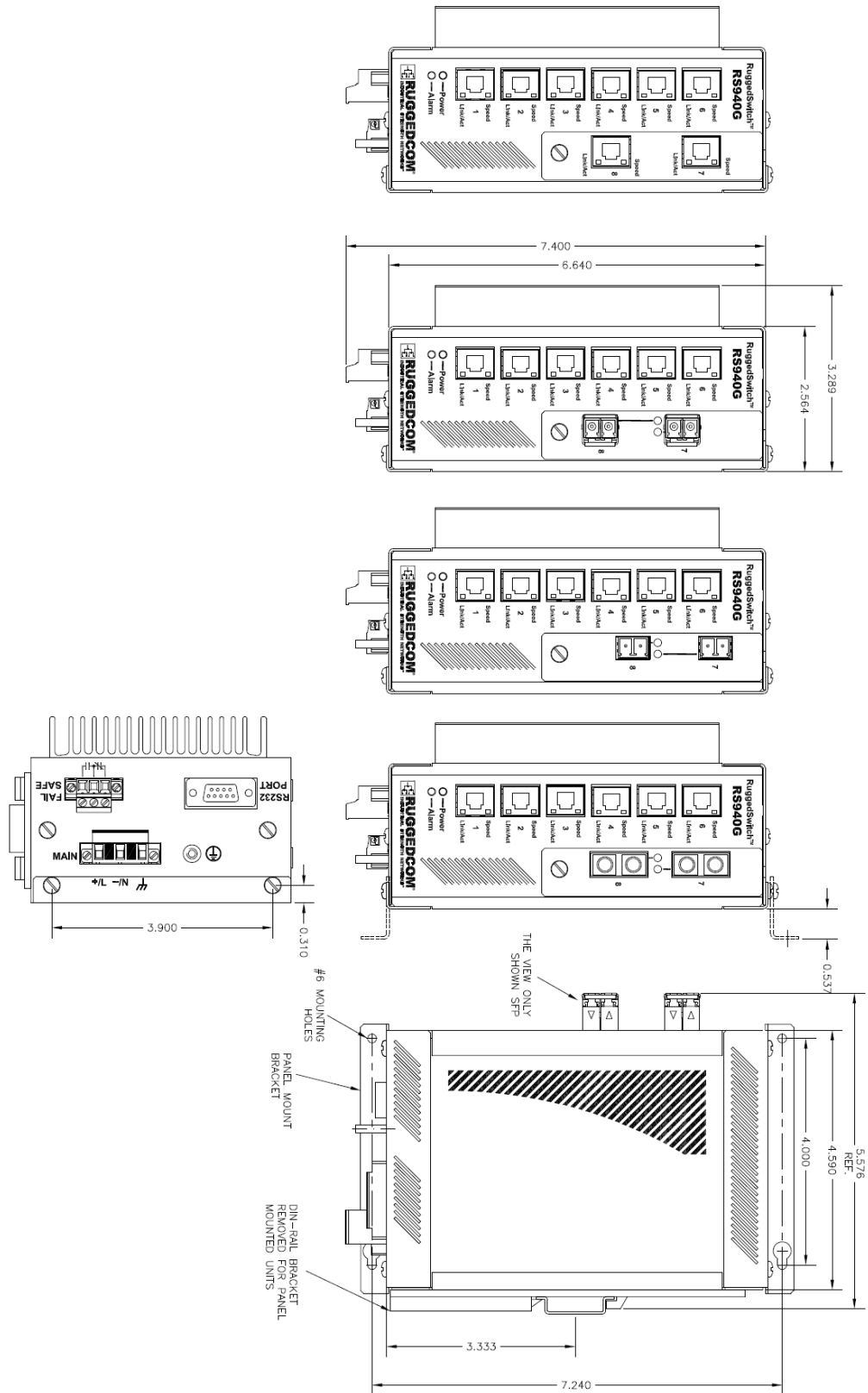

Figure 16 - Mechanical Specifications

4 Type Tests

4.1 IEC 61850-3 Type Tests

Test	Description		Test Levels	Severity Levels
IEC 61000-4-2	ESD	Enclosure Contact	+/- 8kV	4
		Enclosure Air	+/- 15kV	4
IEC 61000-4-3	Radiated RFI	Enclosure ports	20 V/m	x
IEC 61000-4-4	Burst (Fast Transient)	Signal ports	+/- 4kV @ 2.5kHz	x
		D.C. Power ports	+/- 4kV	4
		A.C. Power ports	+/- 4kV	4
		Earth ground ports	+/- 4kV	4
IEC 61000-4-5	Surge	Signal ports	+/- 4kV line-to-earth, +/- 2kV line-to-line	4
		D.C. Power ports	+/- 2kV line-to-earth, +/- 1kV line-to-line	3
		A.C. Power ports	+/- 4kV line-to-earth, +/- 2kV line-to-line	4
IEC 61000-4-6	Induced (Conducted) RFI	Signal ports	10V	3
		D.C Power ports	10V	3
		A.C. Power ports	10V	3
		Earth ground ports	10V	3
IEC 61000-4-8	Magnetic Field	Enclosure ports	40 A/m continuous, 1000 A/m for 1 s	N/A
IEC 61000-4-29	Voltage Dips & Interrupts	D.C. Power ports	30% for 0.1s, 60% for 0.1s, 100% for 0.05s	N/A
IEC 61000-4-11		A.C. Power ports	30% for 1 period, 60% for 50 periods 100% for 5 periods, 100% for 50 periods ²	N/A
IEC 61000-4-12	Damped Oscillatory	Signal ports	2.5kV common, 1kV differential mode @ 1MHz	3
		D.C. Power ports	2.5kV common, 1kV differential mode @ 1MHz	3
		A.C. Power ports	2.5kV common, 1kV differential mode @ 1MHz	3
IEC 61000-4-16	Mains Frequency Voltage	Signal ports	30V Continuous, 300V for 1s	4
		D.C. Power ports	30V Continuous, 300V for 1s	4
IEC 61000-4-17	Ripple on D.C. Power Supply	D.C. Power ports	10%	3
IEC 60255-5	Dielectric Strength	Signal ports	2kVac (Fail-Safe Relay output)	N/A
		D.C. Power ports	1.5kVDC	N/A
		A.C. Power ports	2kVAC	N/A
IEC 60255-5	H.V. Impulse	Signal ports	5kV (Fail-Safe Relay output)	N/A
		D.C. Power ports	5kV	N/A
		A.C. Power ports	5kV	N/A

Table 10 - IEC 61850-3 Type Tests

4.2 IEEE 1613 Type Tests

Test	Description		Test Levels
IEEE C37.90.3	ESD	Enclosure Contact	+/- 8kV
		Enclosure Air	+/- 15kV
IEEE C37.90.2	Radiated RFI	Enclosure ports	35 V/m
IEEE C37.90.1	Fast Transient	Signal ports	+/- 4kV @ 2.5kHz
		D.C. Power ports	+/- 4kV
		A.C. Power ports	+/- 4kV
		Earth ground ports	+/- 4kV
IEEE C37.90.1	Oscillatory	Signal ports	2.5kV common mode @ 1MHz
		D.C. Power ports	2.5kV common & differential mode @ 1MHz
		A.C. Power ports	2.5kV common & differential mode @ 1MHz
IEEE C37.90	H.V. Impulse	Signal ports	5 kV (Failsafe Relay)
		D.C. Power ports	5 kV
		A.C. Power ports	5 kV
IEEE C37.90	Dielectric Strength	Signal ports	2kVac (Failsafe Relay)
		D.C. Power ports	1.5kVDC
		A.C. Power ports	2kVAC

Table 11 - IEEE 1613 Type Tests

NOTE:

- If the unit contains copper ports the IEEE 1613 conformance is Class 1 (During disturbance errors may occur but recovery is automatic).
- If the unit contains all fiber ports the IEEE 1613 conformance is Class 2 (During disturbance no errors will occur).

4.3 IEC Environmental Type Tests

Test	Description		Test Levels	Severity Levels
IEC 60068-2-1	Cold Temperature	Test Ad	-40 deg. C, 16 Hours	N/A
IEC 60068-2-2	Dry Heat	Test Bd	+85 deg. C, 16 Hours	N/A
IEC 60068-2-30	Humidity (Damp Heat, Cyclic)	Test Db	95% (non-condensing), 55 deg C, 6 cycles	N/A
IEC 60255-21-1	Vibration		2g @ (10-150) Hz	Class 2
IEC 60255-21-2	Shock		30g @ 11ms	Class 2

Table 12 - Environmental Type Tests

5 Warranty

RuggedCom warrants this product for a period of five (5) years from date of purchase. For warranty details, visit <http://www.ruggedcom.com> or contact your customer service representative. Should this product require warranty or service contact the factory at:

RuggedCom Inc.
300 Applewood Crescent
Concord, Ontario
Canada L4K 5C7

Phone: +1 905 856 5288
Fax: +1 905 856 1995