



RuggedSwitch® RSG2288

Modular 9 Port Managed Gigabit Ethernet Switch with IEEE 1588 v2 Precision Timing

Product Overview



The RSG2288 is the ideal product to increase the performance and accuracy of the timing for IEC 61850 Process Bus applications. With up to nine high speed Gigabit Ethernet ports, the RSG2288 is designed to meet the increasing speeds of raw Sampled Value data throughput of merging units IEDs. Supporting VLANs and IGMP snooping to channel IED multicast traffic to only intended recipients, the RSG2288 optimizes traffic flow on the process bus, preventing processing overload to slower devices. Combining the high rate Sampled Value data with 1us accuracy hardware assisted time stamping is a powerful feature that provides time synchronized information for processing by associated protection and control IEDs or the Station Computer.

With the optional GPS Time Sync card, the RSG2288 becomes the network Grand Master clock source and provides the ultimate flexibility and redundancy options for designing the timing network while reducing the overall network cost and device count. With built-in IRIG-B, the RSG2288 future proofs the timing network, providing migration from IRIG-B to the latest IEEE standard. Certified with both IEC 61850 and IEEE 1613 electric utility substation standards, the RSG2288 provides uninterrupted operation and keeps mission critical substation IEDs in sync. The RSG2288 is ideally suited to implementation of the IEC 61850 utility substation network as a part of the Smart Grid solution.

Features:

Precision Timing:

- GPS, 1588 v2, IRIG-B or NTP clock source
- Master, Slave and Transparent Clock operation
- 1µs accuracy

Substation Rated:

- IEC 61850-3
- IEEE 1613
- -40 to +85C operating (no fans)
- Zero-Packet-Loss

Port Features:

- Modular – Up to 9 10/100/1000 ports
- All ports available in copper and multimode or singlemode fiber
- MAC or 802.1x authentication
- VLANs, QoS, Link Aggregation

Management:

- Radius or TACACS user authentication
- SSH/SSL encryption
- Web-based, Telnet, CLI, SNMP, RMON
- Alarms, Critical Relay

Industrial Design:

- 19 inch rack, Panel or DIN mounting
- Front or rear ports
- Top or Bottom LED display panel
- Dual redundant, load sharing, multi-source power supplies

Support and Service:

- 5 Year Warranty
- Global 24x7x365 Technical Action Center
- Personalized Support

Benefits and Applications

Precision Timing – the RSG2288 provides the most options available for integrating precision timing on the substation network allowing multiple clock modes and 1588 v2 devices or IRIG-B distribution.

- Master Clock – 1588 v2, IRIG-B, NTP or GPS clock inputs provide choice of utilizing existing clock sources or providing GPS Grand Master clock functionality right at the substation.
- Transparent Clock – minimizes jitter of the timing signal as it travels through the switch network by compensating for switch residency time that can vary with network load
- Slave / ordinary clock – slave functionality synchronizes with the master and compensates for propagation time, ordinary clock is synchronized and keeps running even if network sync signals are lost

Highest Availability – the RSG2288 provides stable performance under the high levels of temperature variations, EMI stress and voltage fluctuations that occur in substations and provides resiliency for when problems do occur.

- Maintains uninterrupted communication with Zero-Packet-Loss under heavy EMI stress when critical, time-sensitive communication is needed the most
- Enhanced Rapid Spanning Tree provides faster convergence than regular RSTP and supports any network architecture
- Integrated, dual redundant power supplies with a range of supply voltages and connection options ensures continued operation from multiple sources

Flexibility in Substation Design – configure the RSG2288 to meet any design criteria from network architecture to mounting and connecting to substation equipment.

- Full Port Modularity offers the widest selection of copper, short or long haul fiber optic connectors and cables for ease of network design
- Up to 9 Gigabit Ethernet ports makes the RSG2288 ideal for high speed Process Bus applications
- Rack, DIN rail or panel mounting; front or top LED display; front or back Ethernet connections accommodate any installation requirement

Secure Substation Networks – the RSG2288 provides the means to secure management traffic and provide security at the port level.

- Ports are secured with MAC based or 802.1x authentication to prevent network access from unknown or unauthorized devices
- Radius or TACACS provides user authentication and access privileges for switch management; encrypted password protection through SSH / SSL
- SNMP v3 provides authentication and encryption of management traffic

Substation Performance – the RSG2288 is rich with features to optimize the performance of the substation network.

- Using VLANs and Quality of Service the IEC 61850 Process Bus and Station Bus traffic is kept separate and prioritized to minimize latency for time sensitive traffic and maintain bandwidth for data intensive instrumentation
- IGMP Snooping channels IED multicast traffic only to intended subscribers; preserving network bandwidth and preventing host flooding
- Automation and SCADA specific protocol support such as DHCP option 82 and Modbus TCP facilitates integration with other industrial Ethernet devices

Remote Management – the RSG2288 is designed to reside in the substation environments and to be managed remotely and securely.

- Event Logging and Alarms – are configurable and provide a snapshot of critical events that have occurred at the switch including link failure and recovery, unauthorized access attempts or broadcast storm detection
- HTML Web Browser and Telnet User Interfaces – provide a simple and intuitive method for remote configuration and monitoring complete with on-line help
- Configuration File – in text editable format allows remote backup and restore capabilities to the switch
- Port Statistics and RMON – provides continuous statistics per allow data collection and analysis of network traffic patterns
- SNMP v3 support – provides a standardized and secure method for remote management from RuggedCom's RuggedNMS™ or other third party NMS

Timing Distribution with the RSG2288

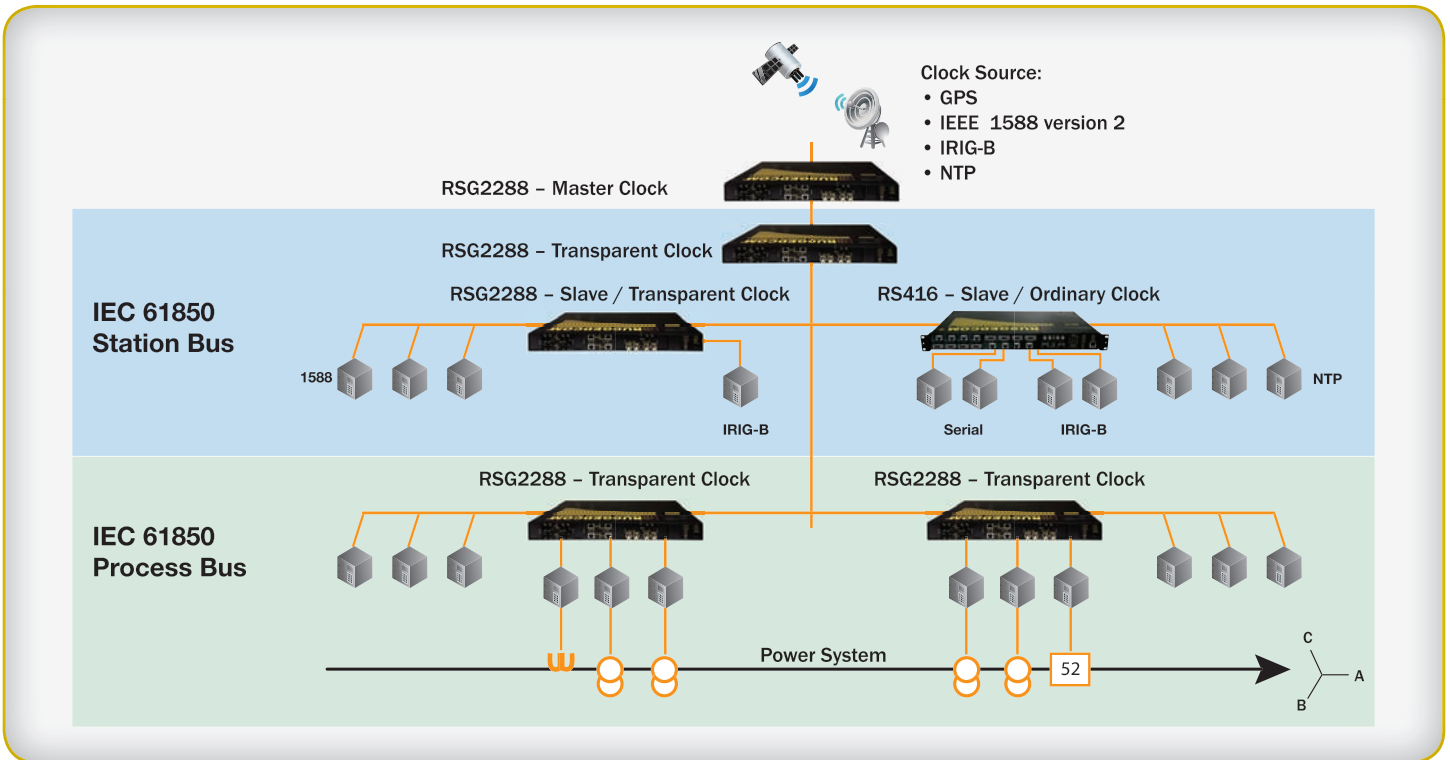

Figure 1. In an typical IEC 61850 application the RSG2288 provides 1 μ s accuracy for synchronization of Station Bus and Process Bus IEDs. The RSG2288 provides distribution of both IEEE 1588 v2 and IRIG-B precision timing for implementing and migrating to the state of the art timing standard.

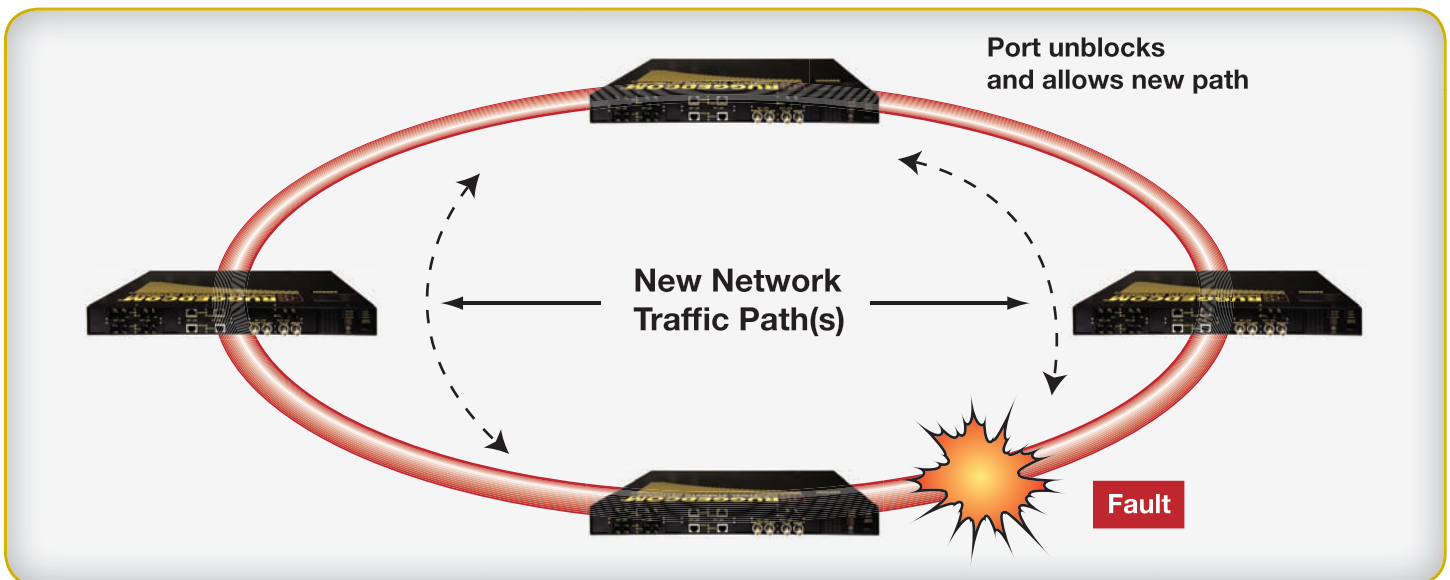

Figure 2. With the RSG2288 ring or mesh network architectures can be built to increase fault tolerance. Compatible with IEEE 802.1w, RuggedCom's enhanced Rapid Spanning Tree Protocol has a faster convergence time of < 5ms per hop and larger ring size up to 80 switches to handle the recovery time required by large networks.



RUGGEDCOM[®]
INDUSTRIAL STRENGTH NETWORKS™

RuggedSwitch[®] RSG2288

Modular 9 Port Managed Gigabit Ethernet Switch with IEEE 1588 v2 Precision Timing

RuggedCom Inc.

300 Applewood Cres., Unit 1
Concord, ON, Canada, L4K 5C7

Tel: +1 (905) 856-5288 **Fax:** +1 (905) 856-1995

Toll Free: 1 (888) 264-0006

Technical Support Center: 1 (866) 922-7975

© 2009 RuggedCom Inc.

RuggedSwitch is a Registered trademark of RuggedCom Inc.

Ethernet is a trademark of the Xerox Corporation.

Patent Pending

All specifications in this document are subject to change without notice.

Rev 1A -10292009

For additional information on our products and services, please visit our website at: www.RuggedCom.com

